

Solenoid coil acc. to VDE 0580

- With integrated amplifier electronics PD2
- Protection class IP 67

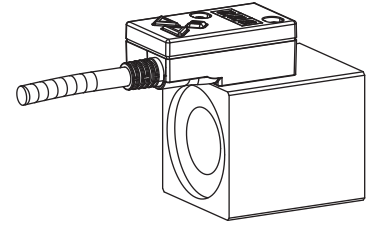

DESCRIPTION

Solenoid coil with integrated amplifier electronics. Protection class is IP67. The electronics are fix mounted on the solenoid coil. The construction corresponds to standard VDE 0580. The steel housing is zinc nickel coated.

FUNCTION

The electronics has a Pulse-Width-Modulated current output. The solenoid output can also be parameterised for switching solenoids. The parameterisation is carried out directly on the device by means of push-buttons and display, or by means of the parameterisation and diagnostics software „PASO” of Wandfluh.

APPLICATION

Due to its water spray resistant execution, the solenoid coil is suitable for most diverse applications.

It can be used on all proportional valves with 19 mm, 23 mm resp. 31 mm armature tube diameters.

Easy connecting enables assembly and commissioning with conventional tools. All settings can be carried out easily and quickly.

TYPE CODE

		M	P		-	P	1	-		#	
Metal housing square											
Integrated amplifier electronics											
Coil execution											
Square 35 mm	S35/19x50			Square 60 mm		S60/31x72					
Square 45 mm	S45/23x50			Square 60 mm		A60/31x72*					
Connection cable vaway from the solenoid											
1-solenoid execution											
Nominal voltage U _N	12 VDC		12								
	24 VDC		24								
Analogue input CANopen acc. to DSP-408 with J1939	voltage/current (0...5V factory preset)		A1								
			C1								
			J1								(on request)
Design index (subject to change)											

* only for proportional pool valve NG10

GENERAL SPECIFICATIONS

Connections	Connection cable	5 x 0,34 mm ² , Exterior coating PVC length = 1,5 m
	USB interface	via connection «Digital input» requires the Wandfluh USB adapter PD2
Dimensions	See drawing page 3	
Ambient temperature		-20...+85 °C

Архангельск (8182)63-90-72
Астана (7172)727-132
Астрахань (8512)99-46-04
Барнаул (3852)73-04-60
Белгород (4722)40-23-64
Брянск (4832)59-03-52
Владивосток (423)249-28-31
Волгоград (844)278-03-48
Вологда (8172)26-41-59
Воронеж (473)204-51-73
Екатеринбург (343)384-55-89
Иваново (4932)77-34-06

Ижевск (3412)26-03-58
Иркутск (395)279-98-46
Казань (843)206-01-48
Калининград (4012)72-03-81
Калуга (4842)92-23-67
Кемерово (3842)65-04-62
Киров (8332)68-02-04
Краснодар (861)203-40-90
Красноярск (391)204-63-61
Курск (4712)77-13-04
Липецк (4742)52-20-81

Магнитогорск (3519)55-03-13
Москва (495)268-04-70
Мурманск (8152)59-64-93
Набережные Челны (8552)20-53-41
Нижний Новгород (831)429-08-12
Новокузнецк (3843)20-46-81
Новосибирск (383)227-86-73
Омск (3812)21-46-40
Орел (4862)44-53-42
Оренбург (3532)37-68-04
Пенза (8412)22-31-16

Пермь (342)205-81-47
Ростов-на-Дону (863)308-18-15
Рязань (4912)46-61-64
Самара (846)206-03-16
Санкт-Петербург (812)309-46-40
Саратов (845)249-38-78
Севастополь (8692)22-31-93
Симферополь (3652)67-13-56
Смоленск (4812)29-41-54
Сочи (862)225-72-31
Ставрополь (8652)20-65-13

Сургут (3462)77-98-35
Тверь (4822)63-31-35
Томск (3822)98-41-53
Тула (4872)74-02-29
Тюмень (3452)66-21-18
Ульяновск (8422)24-23-59
Уфа (347)229-48-12
Хабаровск (4212)92-98-04
Челябинск (351)202-03-61
Череповец (8202)49-02-64
Ярославль (4852)69-52-93

Киргизия (996)312-96-26-47

Россия (495)268-04-70

Казахстан (772)734-952-31

<https://wandfluh.nt-rt.ru/> || wha@nt-rt.ru

Amplifier with analogue interface

ELECTRICAL SPECIFICATIONS

Protection class IP67 acc. to EN 60 529 Supply voltage 8...32 V Residual ripple < +/-5 % Fuse low No-load current approx. 20 mA Max. current consumption No-load current + 2,5 A per solenoid Analogue input 1 input non-differential Voltage / current (switchable by means of parameter) 0...+/- 10V or 0/4...20mA Resolution 10-Bit Input resistance Voltage input >100 kΩ (Input current < 5 mA) Load for current input = 124 Ω Stabilised output voltage 5 VDC max. load 20 mA Solenoid current: • Minimal current I_{min} Adjustable 0... I_{max} mA Factory setting 30 mA • Maximal current I_{max} Adjustable I_{min} ...2450 mA MP35/19x50-...-12, Factory setting 1360 mA MP35/19x50-...-24, Factory setting 680 mA MP45/23x50-...-12, Factory setting 1490 mA MP45/23x50-...-24, Factory setting 780 mA MPS60/31x72-...-12, Factory setting 2290 mA MPA60/31x72-...-12, Factory setting 2290 mA MPS60/31x72-...-24, Factory setting 1140 mA MPA60/31x72-...-24, Factory setting 1140 mA	Dither Frequency adjustable 4...500 Hz Factory setting 80 Hz Level adjustable 0...400 mA Factory setting 180 mA Temperature drift <1% at $\Delta T = 40^\circ C$ Digital inputs 1 input high-active, no pull-up/down Switching threshold high 6...32 VDC Switching threshold low 0...1 VDC Usable as frequency input (frequency 5...5000 Hz) and as PWM input (automatic frequency recognition) Ramps Adjustable 0...500 s USB interface Via digital input Requires the Wandfluh USB adapter EMV Immunity EN 61 000-6-2 Emission EN 61 000-6-4	
---	--	--

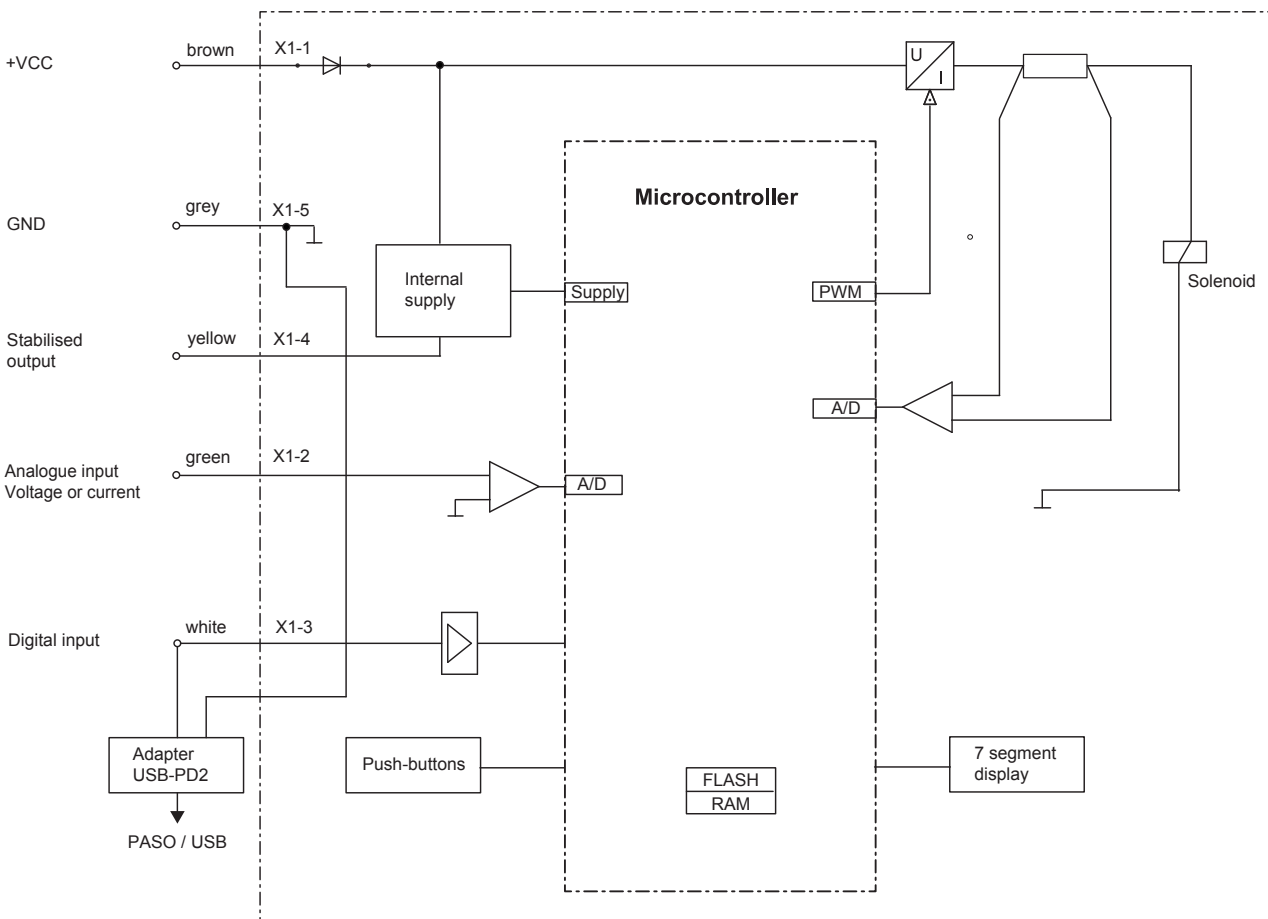
BLOCK DIAGRAM

ABMESSUNGEN

MP.60/31x72

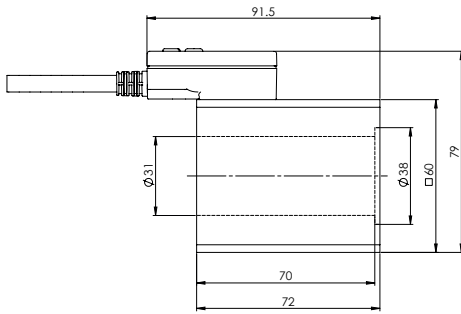

MPS45/23x50

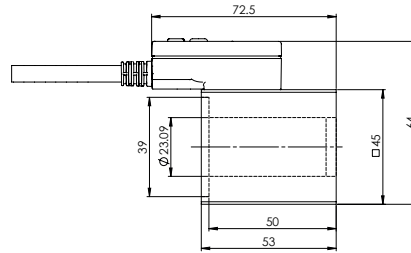

MPS35/19x50

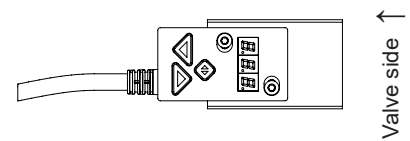
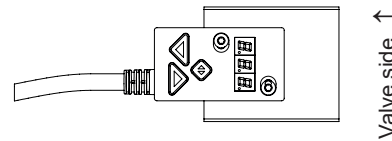
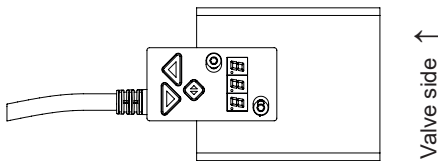
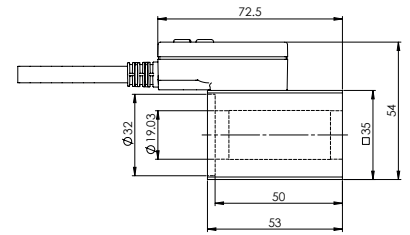

CONNECTOR ASSIGNMENT

Connection cable

- 1 brown
- 2 green
- 3 white
- 4 yellow
- 5 grey

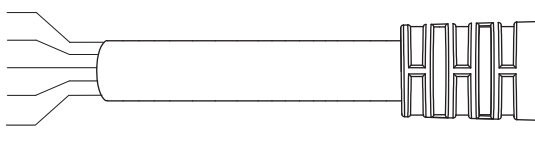

- 1 = + VCC
- 2 = Command value
- 3 = Dig Inp
- 4 = Stab out
- 5 = GND

START-UP

Information regarding installation and commissioning are contained in the information leaflet supplied with the amplifier electronics and in the operating instructions.

Additional information can be found on our website:

Free-of-charge download:

- «PASO-PD2» Parameterisation software
- Operating instruction (*.pdf)

ADDITIONAL INFORMATION

Wandfluh electronics general

Wandfluh documentation-
register 1.13

Proportional spool valve
Proportional pressure valves
Proportional flow control valves

register 1.10
register 2.3
register 2.6

ACCESSORIES

USB-adapter PD2
incl. USB-cable type A-B, 1,8 m
(for parameterisation via PASO)

Article no. 726.9900

PARAMETER SETTINGS

The PD2 electronics have push-buttons and a 7 segment display which enable setting the most important parameters. In addition, the digital input can be used as a communication interface, through which, by means of the parameterisation software „PASO-PD2“, the complete parameterisation and diagnostics can be carried out. For this, the Wandfluh USB-PD2 adapter is required. (not included in the delivery)

Attention: During the communication, the digital input cannot be used.

FUNCTION DESCRIPTION

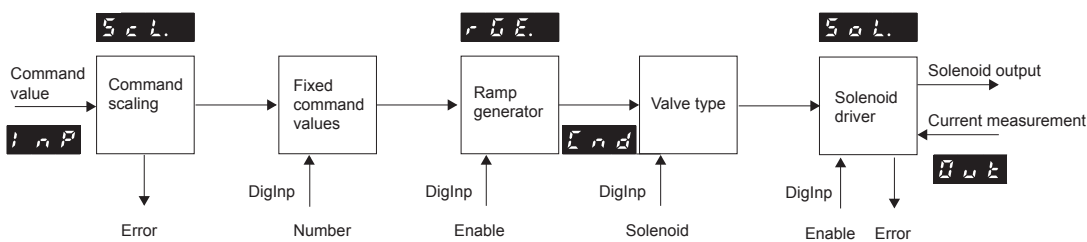

PD2-AMPLIFIER WITH ANALOGUE INTERFACE
Command value scaling

The command value can be applied as a voltage, current, digital, frequency or PWM signal. The scaling takes place via the parameter "Interface". Furthermore, the command value can be monitored for a cable break. A dead band can also be set.

Fixed command value

There is 1 fixed command value available, which can be selected via the digital input. This function has to be configured before in PASO.

Ramp generator

Two linear ramps for up and down are available which can be adjusted separately.

Valve type

Adjustment possibilities: switching solenoid or proportional solenoid.

Mode of operation „Command value unipolar/bipolar (1-Sol)

Dependent on a command value signal (voltage, current, digital, frequency or PWM), the solenoid is driven (e.g. 0...10V correspond to 0...100 % command value, 0...+100 % command value correspond to I_{min}...I_{max} solenoid driver)

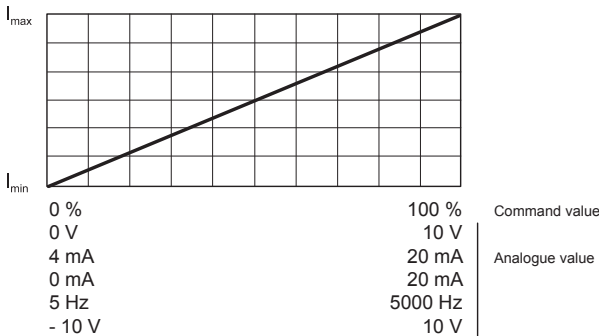
Signal recording

Furthermore, the „PD2“ amplifier electronics have a signal recording function. This, by means of PASO, enables the recording of various system signals, such as command value, solenoid current, etc., which can be represented on a common time axis.

Solenoid driver

A Pulse-Width-Modulated current output is available. A dither signal is superimposed, whereby the dither frequency and the dither level are separately adjustable. The minimum (I_{min}) and maximum (I_{max}) current can be adjusted. The solenoid output can also be configured as switching solenoid output. In this case, a power reduction can be adjusted.

Optimisation of characteristic curve

An adjustable characteristic curve „Command value input – solenoid current output“ enables an optimised (e.g. linearised) characteristic of the hydraulic system.

Channel enabling

As per factory setting, the device is enabled („on“). This „enable channel“ can be set to „on“, „off“ or „external“ (digital input) via PASO or via menu item.

Hints:

Digital input: if not wired, the state of the digital input is not defined
 Analogue input: if not wired, the voltage input will read 1.11 V constantly.

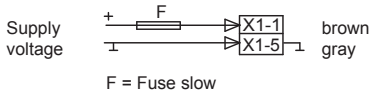
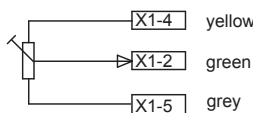
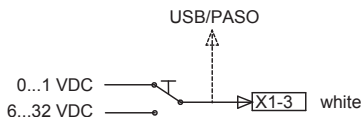
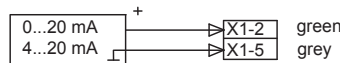
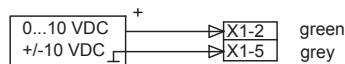
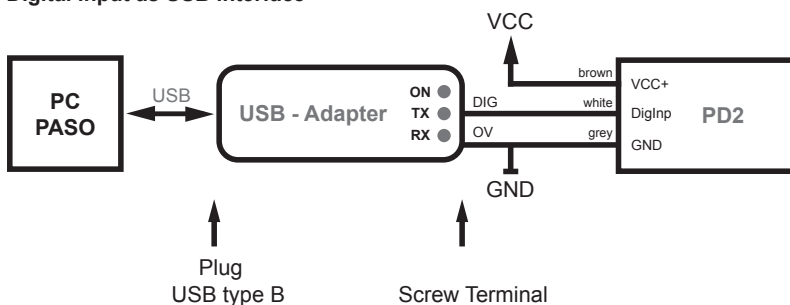
CONNECTION EXAMPLES
Supply voltage

Analogue input with potentiometer

Digital input as function input

Analogue input current with external current source

Analogue input voltage with external voltage source

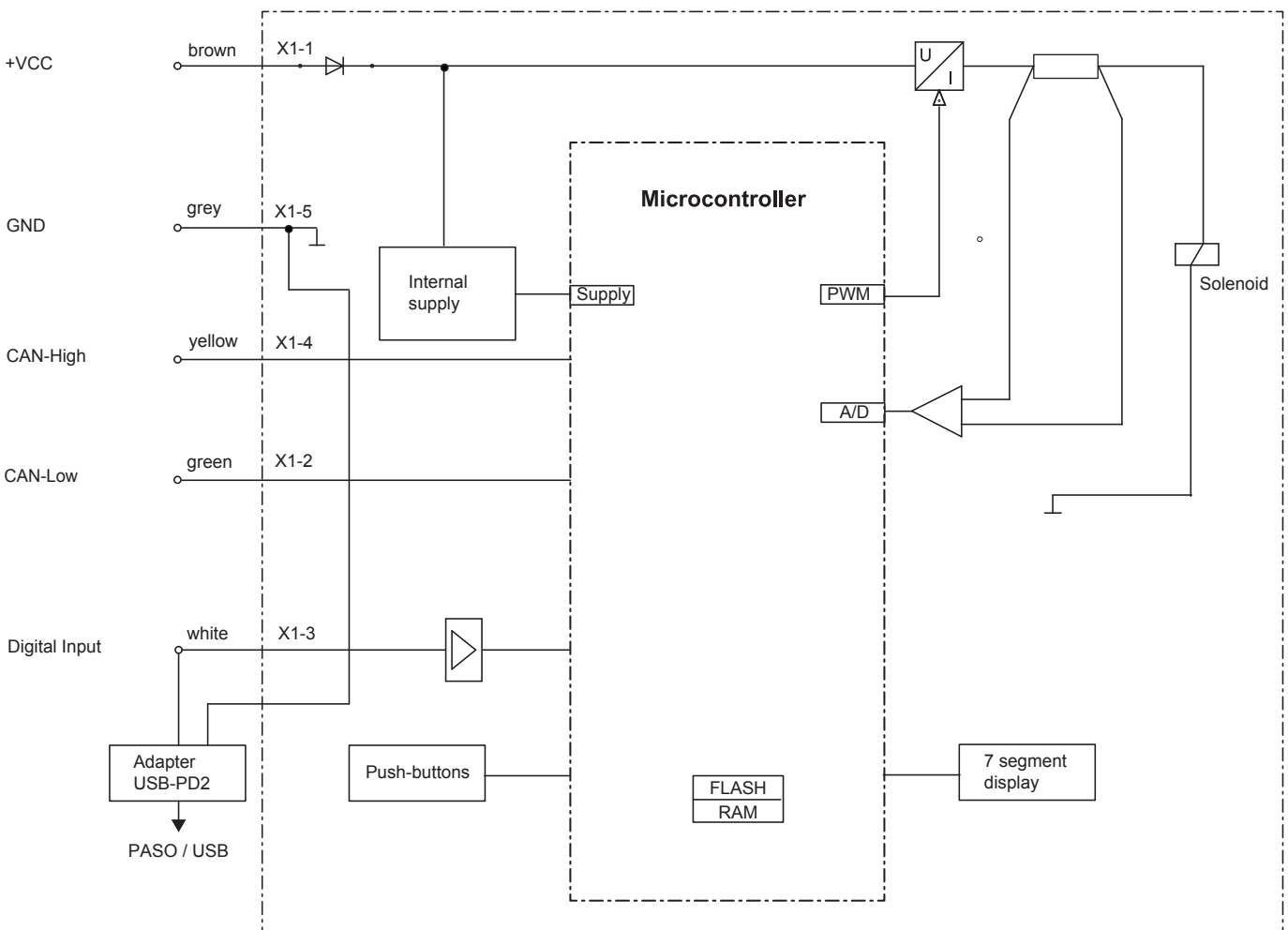
Digital input as USB interface

Amplifier with CANopen interface

ELECTRICAL SPECIFICATIONS

Protection class	IP67 acc. to EN 60 529	Dither	Frequency adjustable 4...500 Hz Factory setting 80 Hz
Supply voltage	8...32 V	Temperature drift	Level adjustable 0...400 mA Factory setting 180 mA
Residual ripple	< +/-5 %	Digital inputs	<1% at $\Delta T = 40^\circ C$ 1 input high-active, no pull-up/down Switching threshold high 6...32 VDC Switching threshold low 0...1 VDC Usable as frequency input (frequency 5...5000 Hz) and as PWM input (automatic frequency recognition)
Fuse	low	USB interface	Via digital input Requires the Wandfluh USB adapter
No-load current	approx. 20 mA	EMV	
Max. current consumption	No-load current + 2,5 A per solenoid	Immunity	EN 61 000-6-2
		Emission	EN 61 000-6-4
Solenoid current:			
• Minimal current I_{min}	Adjustable 0... I_{max} mA Factory setting 30 mA		
• Maximal current I_{max}	Adjustable I_{min} ...2450 mA MP35/19x50-...-12, Factory setting 1360 mA MP35/19x50-...-24, Factory setting 680 mA MP45/23x50-...-12, Factory setting 1490 mA MP45/23x50-...-24, Factory setting 780 mA MPS60/31x72-...-12, Factory setting 2290 mA MPA60/31x72-...-12, Factory setting 2290 mA MPS60/31x72-...-24, Factory setting 1140 mA MPA60/31x72-...-24, Factory setting 1140 mA		

BLOCK DIAGRAM



DIMENSIONS

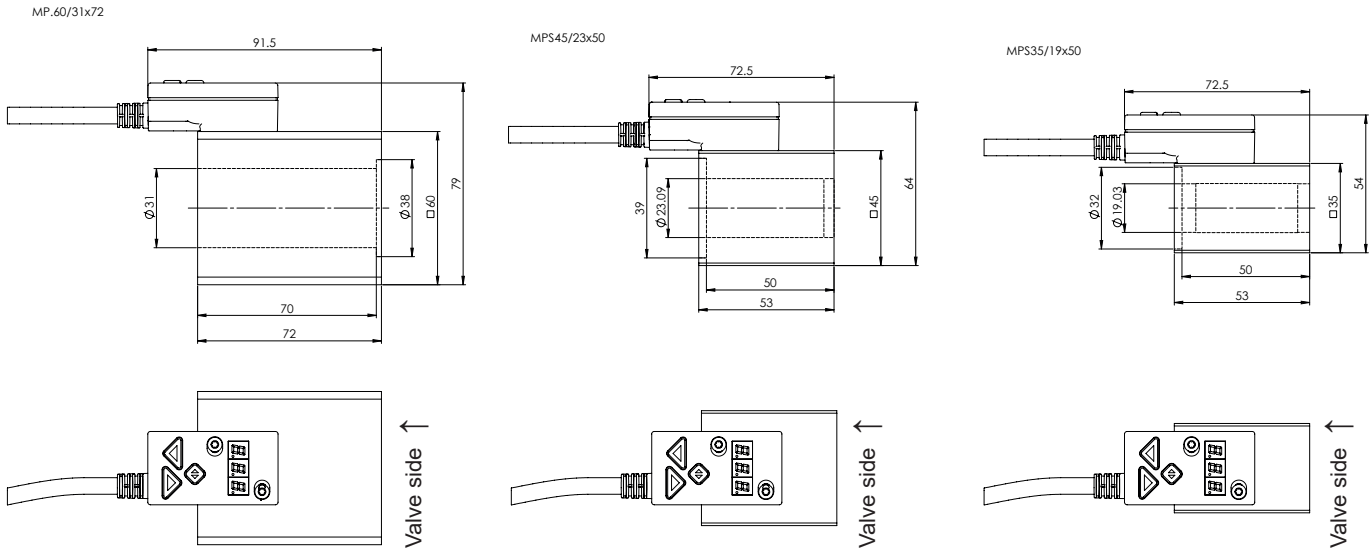

ANSCHLUSSBELEGUNG

Anschlusskabel

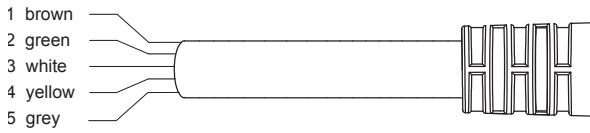

- 1 = + VCC
- 2 = CAN-Low
- 3 = Dig Inp
- 4 = CAN-High
- 5 = GND

START-UP

Information regarding installation and commissioning are contained in the information leaflet supplied with the amplifier electronics and in the operating instructions.

Additional information can be found on our website:

Free-of-charge download:

- «PASO-PD2» Parameterisation software
- Operating instruction (*.pdf)

ADDITIONAL INFORMATION

Wandfluh electronics general	Wandfluh documentation-register	1.13
Proportional spool valve	register	1.10
Proportional pressure valves	register	2.3
Proportional flow control valves	register	2.6

ACCESSORIES

USB-adapter PD2 incl. USB-cable type A-B, 1,8 m (for parameterisation via PASO)	Article no. 726.9900
---	----------------------

PARAMETER SETTINGS

The PD2 electronics have push-buttons and a 7 segment display which enable setting the most important parameters. In addition, the digital input can be used as a communication interface, through which, by means of the parameterisation software „PASO-PD2“, the complete parameterisation and diagnostics can be carried out. For this, the Wandfluh USB-PD2 adapter is required. (not included in the delivery)

Attention: During the communication, the digital input cannot be used.

FUNCTION DESCRIPTION

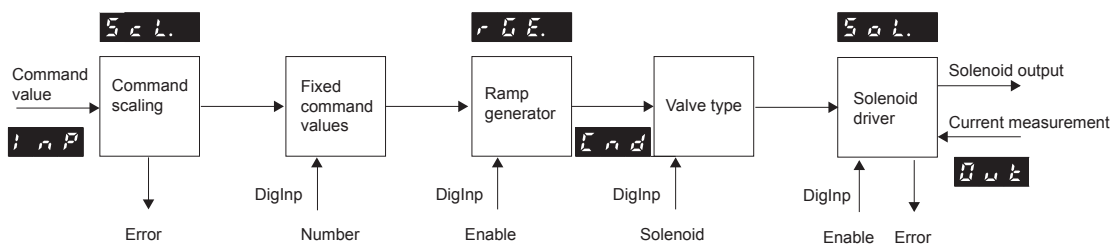

Command value scaling

The command value can be applied as a CAN-bus, digital, frequency or PWM signal. The scaling takes place via the parameter „Interface“. Furthermore, the command value can be monitored for a cable break. A dead band can also be set.

Fixed command value

There is 1 fixed command value available, which can be selected via the digital input. This function has to be configured before in PASO.

Ramp generator

Two linear ramps for up and down are available which can be adjusted separately.

Valve type

Adjustment possibilities: switching solenoid or proportional solenoid.

Mode of operation „Command value unipolar/bipolar (1-Sol)“

Dependent on a command value signal (CAN-bus, digital, frequency or PWM), the solenoid is driven (e.g. 0...16383 CAN-command correspond to 0...100 % command value, 0...+100 % command value correspond to Imin...Imax solenoid driver)

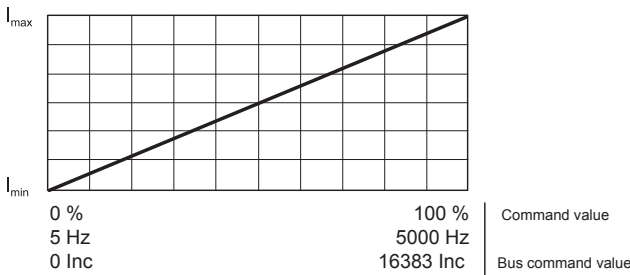

Signal recording

Furthermore, the „PD2“ amplifier electronics have a signal recording function. This, by means of PASO, enables the recording of various system signals, such as command value, solenoid current, etc., which can be represented on a common time axis.

Solenoid driver

A Pulse-Width-Modulated current output is available. A dither signal is superimposed, whereby the dither frequency and the dither level are separately adjustable. The minimum (Imin) and maximum (Imax) current can be adjusted. The solenoid output can also be configured as switching solenoid output. In this case, a power reduction can be adjusted.

Optimisation of characteristic curve

An adjustable characteristic curve „Command value input – solenoid current output“ enables an optimised (e.g. linearised) characteristic of the hydraulic system.

Channel enabling

As per factory setting, the device can be enabled via CAN-bus. This „enable channel“ can be set to „bus“, „on“, „off“ or „external“ (digital input) via PASO or via menu item.

Hint:

Digital input if not wired, the state of the digital input is not defined

CONNECTION EXAMPLES

Supply voltage

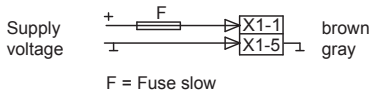

CAN connection

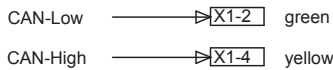

Digital input as function input

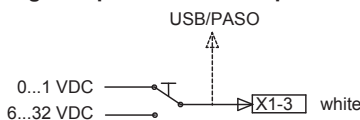

Digital input as USB interface

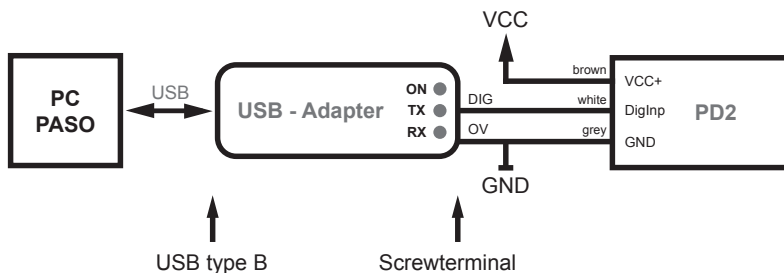

Архангельск (8182)63-90-72
Астана (7172)727-132
Астрахань (8512)99-46-04
Барнаул (3852)73-04-60
Белгород (4722)40-23-64
Брянск (4832)59-03-52
Владивосток (423)249-28-31
Волгоград (844)278-03-48
Вологда (8172)26-41-59
Воронеж (473)204-51-73
Екатеринбург (343)384-55-89
Иваново (4932)77-34-06

Ижевск (3412)26-03-58
Иркутск (395)279-98-46
Казань (843)206-01-48
Калининград (4012)72-03-81
Калуга (4842)92-23-67
Кемерово (3842)65-04-62
Киров (8332)68-02-04
Краснодар (861)203-40-90
Красноярск (391)204-63-61
Курск (4712)77-13-04
Липецк (4742)52-20-81

Магнитогорск (3519)55-03-13
Москва (495)268-04-70
Мурманск (8152)59-64-93
Набережные Челны (8552)20-53-41
Нижегород (831)429-08-12
Новокузнецк (3843)20-46-81
Новосибирск (383)227-86-73
Омск (3812)21-46-40
Орел (4862)44-53-42
Оренбург (3532)37-68-04
Пенза (8412)22-31-16

Пермь (342)205-81-47
Ростов-на-Дону (863)308-18-15
Рязань (4912)46-61-64
Самара (846)206-03-16
Санкт-Петербург (812)309-46-40
Саратов (845)249-38-78
Севастополь (8692)22-31-93
Симферополь (3652)67-13-56
Смоленск (4812)29-41-54
Сочи (862)225-72-31
Ставрополь (8652)20-65-13

Сургут (3462)77-98-35
Тверь (4822)63-31-35
Томск (3822)98-41-53
Тула (4872)74-02-29
Тюмень (3452)66-21-18
Ульяновск (8422)24-23-59
Уфа (347)229-48-12
Хабаровск (4212)92-98-04
Челябинск (351)202-03-61
Череповец (8202)49-02-64
Ярославль (4852)69-52-93

Киргизия (996)312-96-26-47

Россия (495)268-04-70

Казахстан (772)734-952-31