

Proportional-amplifier

- Plug amplifier for direct assembly on the valve
- Protection class IP65
- 24 and 12 VDC supply voltage
- Housing-types for solenoids from □ 29

P02
 DIN 43 650
 ISO 4400

DESCRIPTION

Proportional amplifier for direct assembly on the valve. Pin layout according to DIN 43650, Type A (ISO 4400) for solenoids from □ 29 or larger. Protection class of the plug amplifier is IP65, mounted according to DIN 40050. The connector cable is already mounted in the plug.

FUNCTION

The proportional amplifier has a clock-pulsed final stage. The clock frequency acts as dither and can be steplessly adjusted. Minimum and maximum solenoid current can be adjusted separately. Furthermore, a linear ramp is integrated. By means of the input release/block, the function can be blocked. A stabilized output voltage is available for supplying external pre-set value transmitters.

APPLICATIONS

The amplifier is suitable for different applications because of its splash water proof design. The easyness of connection allows to put it into operation without help of special tools. All settings are easily adjustable. The plug can be rotated by 180°.

CONTENTS

GENERAL SPECIFICATIONS	1
ELECTRICAL SPECIFICATIONS.....	1
BLOCK DIAGRAM.....	2
DIMENSIONS	2
MAX. AMBIENT TEMPERATURE	2
ADDITIONAL INFORMATIONS	2
START-UP	3

TYPE CODE

Plug	P	02	A	0	1	□	□	#	□
Type number									
Housing A for solenoids □ 29 or larger									
with cable connection									
1-solenoid version									
Supply voltage									
24 VDC	24 V proportional solenoid	D2							
12 VDC	12 V proportional solenoid	D3							
Preset value input 0...+ 8 VDC (only for 12 VDC)	3								
Preset value input 0...+ 10 VDC (only for 24 VDC)	4								
Design-Index (Subject to change)									

GENERAL SPECIFICATIONS

Plug housing	polyamide
Plug	polycarbonate
Weight	160 g
Connections	mounted cable, length 1,5 m (on request, cable length 5 m/10 m)
Ambient temperature	see curve max. ambient temp.

ELECTRICAL SPECIFICATIONS

Supply voltage	24 VDC	tolerance: 22...36 VDC
	12 VDC	tolerance: 11...18 VDC
Preset value input	0...+10 VDC	(0...+ 8 VDC)
Input resistance	≥ 100 kΩ	
Stabilized output voltage		
24 V-version:	10 VDC, max. load 2 mA	
12 V-version:	8 VDC, max. load 2 mA	
Dither	frequency adjustable 60...250 Hz	
Works setting	200 Hz	
No load-power	24 VDC: 0,3 W 12 VDC: 0,2 W	
Solenoid current	for 24 Volt solenoid	
	min. current I _{min} adjustable	30..400 mA
	works setting	150 mA
	max. current I _{max} adjustable	I _{min} ..1200 mA
	works setting	700 mA
	for 12 Volt solenoid	
	min. current I _{min} adjustable	80..800 mA
	works setting	300 mA
	max. current I _{max} adjustable	I _{min} ..1800 mA
	works setting	1200 mA
Ramp	1 ramp up/down adjustable with same potentiometer.	
	0,25..6 s.	
Ramp time		
EMC		
Immunity	EN 61 000-6-2	
Emission	EN 61 000-6-4	

Архангельск (8182)63-90-72
 Астана (7172)727-132
 Астрахань (8512)99-46-04
 Барнаул (3852)73-04-60
 Белгород (4722)40-23-64
 Брянск (4832)59-03-52
 Владивосток (423)249-28-31
 Волгоград (844)278-03-48
 Вологда (8172)26-41-59
 Воронеж (473)204-51-73
 Екатеринбург (343)384-55-89
 Иваново (4932)77-34-06

Ижевск (3412)26-03-58
 Иркутск (395)279-98-46
 Казань (843)206-01-48
 Калининград (4012)72-03-81
 Калуга (4842)92-23-67
 Кемерово (3842)65-04-62
 Киров (8332)68-02-04
 Краснодар (861)203-40-90
 Красноярск (391)204-63-61
 Курск (4712)77-13-04
 Липецк (4742)52-20-81

Магнитогорск (3519)55-03-13
 Москва (495)268-04-70
 Мурманск (8152)59-64-93
 Набережные Челны (8552)20-53-41
 Нижний Новгород (831)429-08-12
 Новокузнецк (3843)20-46-81
 Новосибирск (383)227-86-73
 Омск (3812)21-46-40
 Орел (4862)44-53-42
 Оренбург (3532)37-68-04
 Пенза (8412)22-31-16

Пермь (342)205-81-47
 Ростов-на-Дону (863)308-18-15
 Рязань (4912)46-61-64
 Самара (846)206-03-16
 Санкт-Петербург (812)309-46-40
 Саратов (845)249-38-78
 Севастополь (8692)22-31-93
 Симферополь (3652)67-13-56
 Смоленск (4812)29-41-54
 Сочи (862)225-72-31
 Ставрополь (8652)20-65-13

Сургут (3462)77-98-35
 Тверь (4822)63-31-35
 Томск (3822)98-41-53
 Тула (4872)74-02-29
 Тюмень (3452)66-21-18
 Ульяновск (8422)24-23-59
 Уфа (347)229-48-12
 Хабаровск (4212)92-98-04
 Челябинск (351)202-03-61
 Череповец (8202)49-02-64
 Ярославль (4852)69-52-93

Киргизия (996)312-96-26-47

Россия (495)268-04-70

Казахстан (772)734-952-31

BLOCK DIAGRAM

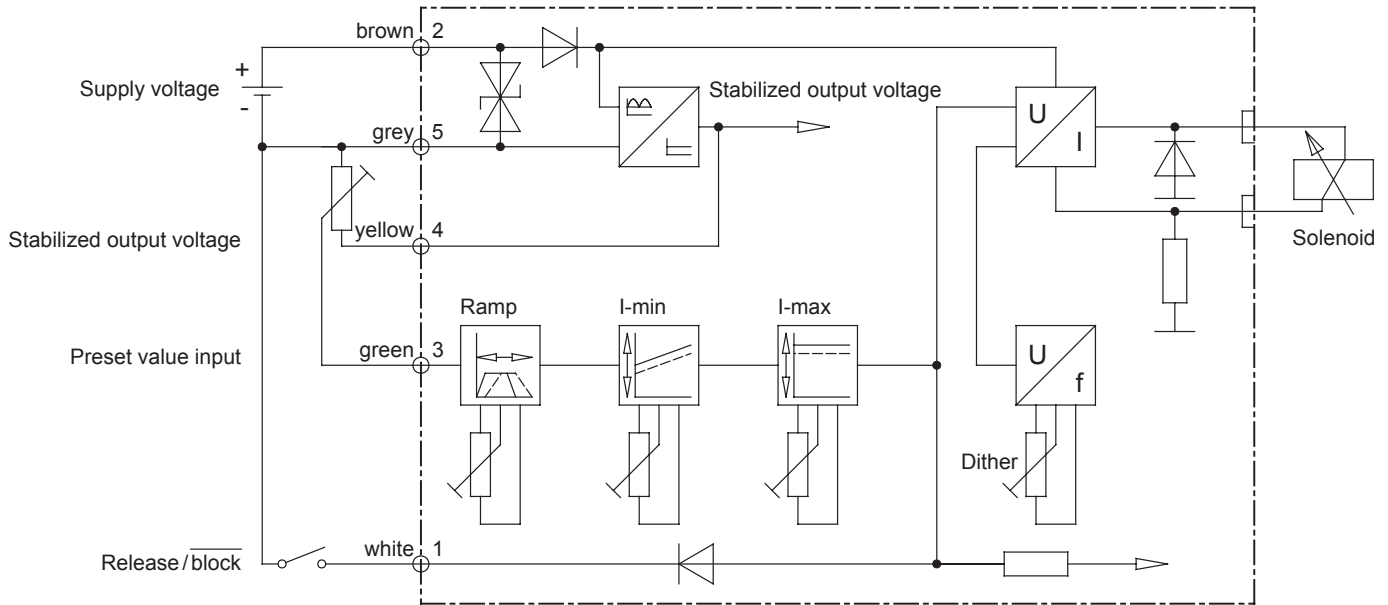

DIMENSIONS

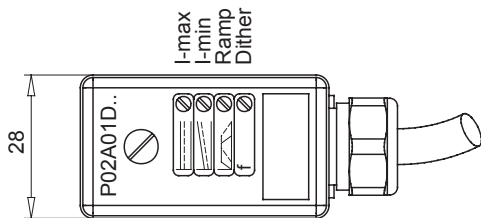
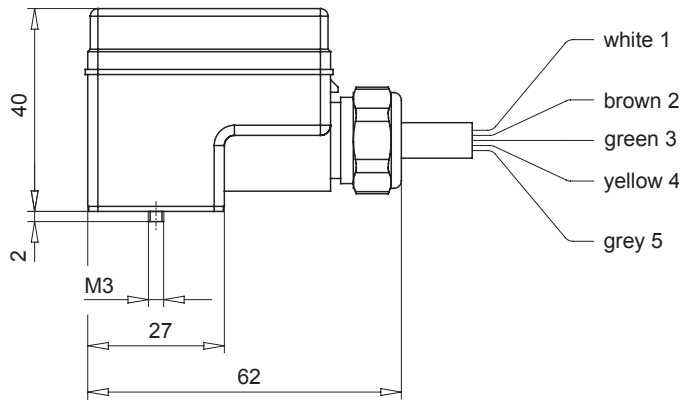

MAX. AMBIENT TEMPERATURE CURVE

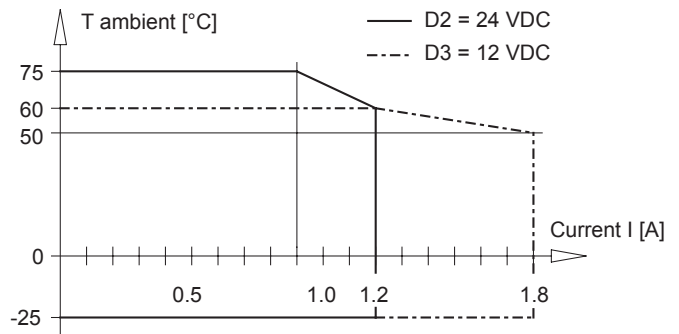

If mounted on the solenoid □ 60/12V the current has to be limited to 1.8 A, otherwise the proportional-amplifier could be overloaded.

ADDITIONAL INFORMATION

Proportional directional control valves	Wandfluh-Dokumentation register	1.10
Proportional pressure control valves	register	2.3
Proportional flow control valves	register	2.6

START-UP

This data sheet is enclosed with each proportional-amplifier.

Connection examples

Connection with external preset value potentiometer

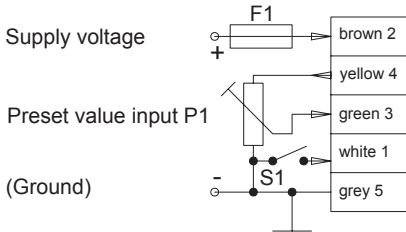
 F1: 24 V = 1,6 A quick-break
 12 V = 2,5 A quick-break
 S1 = release/block

Connection with n preset value potentiometers

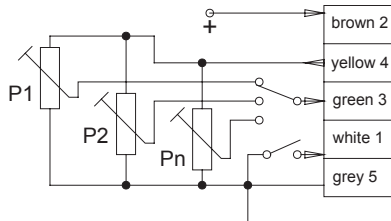
 $P1 - Pn = 50 \text{ k}\Omega$

Connection with preset value switch

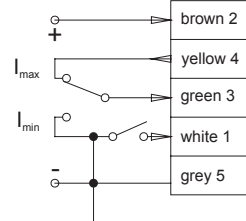

Connection with external power source release/block with PLC, PC or NC

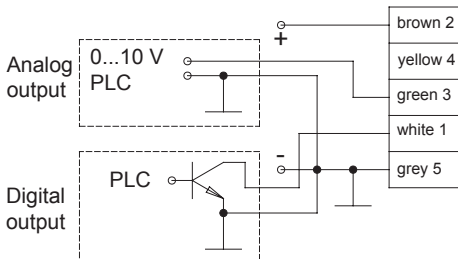

Connection with external current source

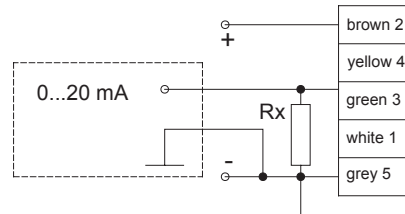
 $Rx = 470 \Omega / 0,5 \text{ W}$ for 24 VDC
 $Rx = 390 \Omega / 0,5 \text{ W}$ for 12 VDC

Connection instructions
Supply voltage (brown, grey)

The connection has to be done as shown above:

- + pole = brown
- pole = grey (Ground)

Stabilized output voltage (yellow)

 The output can be used for supplying an external preset input. The maximum load is 2 mA.
 (R preset input $\geq 5 \text{ k}\Omega$)

Preset value input (green)

The analog preset value signal 0...+10 VDC (0...+8 VDC/12 V-version) has to be connected here.

Release/block (white)

If the line is not connected, the proportional amplifier is released. If the line is connected to ground, the amplifier is blocked.

Mounting

With a screw driver the bottom of the amplifier can be lifted-off and turned by 180°.

Setting instructions
Minimum current I_{\min}

 Adjust the external preset value to 0%. Adjust the solenoid current with the potentiometer I_{\min} to a value which results in the desired minimum output of the consumer.

Maximum current I_{\max}

 Adjust the external preset value to 100%. Adjust the solenoid current with the potentiometer I_{\max} to a value which results in the desired maximum output of the consumer.

Dither

With the potentiometer Dither, adjust the frequency of the modulated solenoid current to the value which results in the desired sensitivity of the consumers.

- Turning the potentiometer to the right: Higher frequency.
- Turning the potentiometer to the left: Lower frequency.

Ramp

There is a common potentiometer mounted for the «ramping up / ramping down» functions.

- Turning the potentiometer to the right: Long ramping time.
- Turning the potentiometer to the left: Short ramping time.

Архангельск (8182)63-90-72
Астана (7172)727-132
Астрахань (8512)99-46-04
Барнаул (3852)73-04-60
Белгород (4722)40-23-64
Брянск (4832)59-03-52
Владивосток (423)249-28-31
Волгоград (844)278-03-48
Вологда (8172)26-41-59
Воронеж (473)204-51-73
Екатеринбург (343)384-55-89
Иваново (4932)77-34-06

Ижевск (3412)26-03-58
Иркутск (395)279-98-46
Казань (843)206-01-48
Калининград (4012)72-03-81
Калуга (4842)92-23-67
Кемерово (3842)65-04-62
Киров (8332)68-02-04
Краснодар (861)203-40-90
Красноярск (391)204-63-61
Курск (4712)77-13-04
Липецк (4742)52-20-81

Магнитогорск (3519)55-03-13
Москва (495)268-04-70
Мурманск (8152)59-64-93
Набережные Челны (8552)20-53-41
Нижний Новгород (831)429-08-12
Новокузнецк (3843)20-46-81
Новосибирск (383)227-86-73
Омск (3812)21-46-40
Орел (4862)44-53-42
Оренбург (3532)37-68-04
Пенза (8412)22-31-16

Пермь (342)205-81-47
Ростов-на-Дону (863)308-18-15
Рязань (4912)46-61-64
Самара (846)206-03-16
Санкт-Петербург (812)309-46-40
Саратов (845)249-38-78
Севастополь (8692)22-31-93
Симферополь (3652)67-13-56
Смоленск (4812)29-41-54
Сочи (862)225-72-31
Ставрополь (8652)20-65-13

Сургут (3462)77-98-35
Тверь (4822)63-31-35
Томск (3822)98-41-53
Тула (4872)74-02-29
Тюмень (3452)66-21-18
Ульяновск (8422)24-23-59
Уфа (347)229-48-12
Хабаровск (4212)92-98-04
Челябинск (351)202-03-61
Череповец (8202)49-02-64
Ярославль (4852)69-52-93

Киргизия (996)312-96-26-47

Россия (495)268-04-70

Казахстан (772)734-952-31