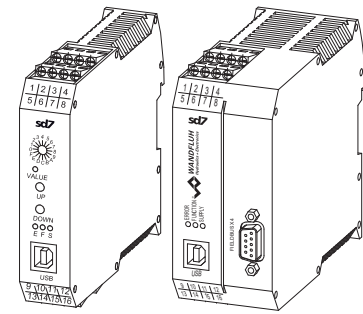

Digital amplifier module SD7

- For 1 or 2 proportional solenoids
- Interface: - analog
 - CANopen / J1939
 - Profibus DP
 - HART
- Max. 4 analog differential inputs
- Max. 8 digital inputs
- Fixed command values
- Adjustable via PC
- (optionally with manual operation on front panel)
- For snapping on to dome rail
- Also available as controller module (see data sheet 1.13-106)

DESCRIPTION

Digital amplifier module for installation on dome rail for controlling proportional or switching valves with one or two solenoids. The parameterisation takes place by means of menu-controlled parameterisation and diagnostics software «PASO» from Wandfluh (USB interface) or optionally with a manual operation on the front panel. Separate ramps for up and down as well as fixed adjustable command values are integrated in the amplifier module as standard. The electronics are optionally available with different fieldbus interfaces.

FUNCTION

The amplifier module has one, resp., two **Pulse-Width-Modulated** current outputs with superimposed dither signal. The solenoid outputs can also be parameterised for switching solenoids. The analog and digital inputs as well as the digital outputs can be programmed individually. With this device control tasks can be solved in a very simple manner. The fieldbus connection enables reading the command value signal as well as the parameterisation directly via the fieldbus.

APPLICATION

As snap-on module, the amplifier module is mainly utilised in the industrial field. The module can be mounted on dome-rails. The connection with terminal screws enables commissioning without special tools in a short time. The amplifier module is particularly suitable for applications with additional functions such as ramps, fixed command values, etc. Customer specific requirements can be implemented in a simple manner.

GENERAL SPECIFICATIONS

Execution	Module for control cubicle, housing made of plastic
Installation	on 35 mm dome rail according to EN 60715
Weight	
• Basic amplifier analog	130 g
• Basic amplifier fieldbus	220 g
• Enhanced amplifier analog	220 g
• Enhanced amplifier fieldbus	240 g
Connections	Screw terminals, max. cable cross-section 2,5 mm ²
Working temperature	-20...+70 °C

Further information can be found in the Operating instructions.

COMMISSIONING

Free-of-charge download:

- «PASO» Parameterisation software
- Operating instructions (.pdf)
- Device description data: (EDS file «WAGSD7C1.eds») (GSD file «SD7-0B8E.gsd»)

ADDITIONAL INFORMATION

Wandfluh electronics general
 Proportional spool valves
 Proportional pressure valves
 Proportional flow valves

Wandfluh documentation
 Register 1.13
 Register 1.10
 Register 2.3
 Register 2.6

Архангельск (8182)63-90-72
 Астана (7172)727-132
 Астрахань (8512)99-46-04
 Барнаул (3852)73-04-60
 Белгород (4722)40-23-64
 Брянск (4832)59-03-52
 Владивосток (423)249-28-31
 Волгоград (844)278-03-48
 Вологда (8172)26-41-59
 Воронеж (473)204-51-73
 Екатеринбург (343)384-55-89
 Иваново (4932)77-34-06

Ижевск (3412)26-03-58
 Иркутск (395)279-98-46
 Казань (843)206-01-48
 Калининград (4012)72-03-81
 Калуга (4842)92-23-67
 Кемерово (3842)65-04-62
 Киров (8332)68-02-04
 Краснодар (861)203-40-90
 Красноярск (391)204-63-61
 Курск (4712)77-13-04
 Липецк (4742)52-20-81

Магнитогорск (3519)55-03-13
 Москва (495)268-04-70
 Мурманск (8152)59-64-93
 Набережные Челны (8552)20-53-41
 Нижний Новгород (831)429-08-12
 Новокузнецк (3843)20-46-81
 Новосибирск (383)227-86-73
 Омск (3812)21-46-40
 Орел (4862)44-53-42
 Оренбург (3532)37-68-04
 Пенза (8412)22-31-16

Пермь (342)205-81-47
 Ростов-на-Дону (863)308-18-15
 Рязань (4912)46-61-64
 Самара (846)206-03-16
 Санкт-Петербург (812)309-46-40
 Саратов (845)249-38-78
 Севастополь (8692)22-31-93
 Симферополь (3652)67-13-56
 Смоленск (4812)29-41-54
 Сочи (862)225-72-31
 Ставрополь (8652)20-65-13

Сургут (3462)77-98-35
 Тверь (4822)63-31-35
 Томск (3822)98-41-53
 Тула (4872)74-02-29
 Тюмень (3452)66-21-18
 Ульяновск (8422)24-23-59
 Уфа (347)229-48-12
 Хабаровск (4212)92-98-04
 Челябинск (351)202-03-61
 Череповец (8202)49-02-64
 Ярославль (4852)69-52-93

Киргизия (996)312-96-26-47

Россия (495)268-04-70

Казахстан (772)734-952-31

TYPE CODE

		S	D7	<input type="checkbox"/>	<input type="checkbox"/>	<input type="checkbox"/>	<input type="checkbox"/>	<input type="checkbox"/>	-	<input type="checkbox"/>	#	<input type="checkbox"/>
Control cubicle												
Digital												
Adjustable with												
• PASO and manual operation (Basic amplifier only, without fieldbus)												
• PASO without manual operation												
Software configuration (function of card):												
• Basic amplifier												
• Enhanced amplifier												
1-solenoid version												
2-solenoid version												
Supply voltage:												
24 VDC												
12 VDC												
Basic amplifier:												
• Analog input 1: voltage												
2: current												
• Analog input 1 and 2: both voltage												
• Analog input 1 and 2: both current												
Analog input 3: always current (with HART only)												
Enhanced amplifier:												
• Analog input 1 and 3: both voltage												
Analog input 2 and 4: both current												
• Analog input 1 to 4: all voltage												
• Analog input 1 to 4: all current												
• Analog input 1 and 2: both voltage												
Analog input 3 and 4: both current												
• Analog input 1 and 2: both current												
Analog input 3 and 4: both voltage												
Analog input 3 and 4: always current (with HART only)												
Basic amplifier without HART												
• Analog input 1 and 2: 10-bit resolution												
Basic amplifier with HART												
• Analog input 1 and 2: 10-bit resolution												
• Analog input 3: 16-bit resolution												
Enhanced amplifier												
• Analog input 1 and 2: 10-bit resolution												
• Analog input 3 and 4: 16-bit resolution												
Option fieldbus:												
• without fieldbus												
• with CANopen												
• with Profibus DP												
• with J1939												
• with HART												
Design-index (Subject to change)												

ELECTRICAL SPECIFICATIONS

Protection class	IP 30 according to EN 60 529	Fieldbus (option)	
Supply voltage	24 VDC or 12 VDC	• Device receptacle	DSUB, 9-pole, CANopen, J1939, Profibus
Voltage range:		• Screw terminals	HART
• 24 VDC	21...30 V	• Bus topology	Line, differential signal transmission
• 12 VDC	10,5...15 V	• Potential separation	500 VDC
Residual ripple	<10 %		
Fuse	Low		
Current consumption:		Solenoid current:	
• No-load current	approx. 40 mA	• Minimal current I_{min}	Adjustable 0...950 mA Factory setting 150 mA
• Maximum current consumption	No-load current + 1,8 A per solenoid (with 24 VDC) No-load current + 2,3 A per solenoid (with 12 VDC)	• Maximal current I_{max}	Adjustable $I_{min}...1,8 A$ (with 24 VDC) $I_{min}...2,3 A$ (with 12 VDC) Factory setting 700 mA
Command value signal: Selectable by means of software		• Accumulated current limitation	The accumulated current of the simultaneously controlled solenoids depends on the ambient temperature. Further information can be found in the Operating instructions.
	Input 1 and 2 Differential input not galvanically separated, for ground potential difference up to 1,5 V 4...+20 mA / 0...+20 mA 0...+10 V (1- or 2-solenoid version) -10...+10 V (2-solenoid version only) Input 3 (option): Galvanically separated for HART signal	Dither	Frequency adjustable 20...500 Hz Factory setting 100 Hz Level adjustable 0...400 mA Factory setting 100 mA
Resolution	10-bit (analog inputs 1 and 2) 16-bit (analog inputs 3 and 4)	Temperature drift	<1 % at $\Delta T = 40 \text{ }^\circ\text{C}$
Input resistance	Voltage input >18 k Ω Load for current input = 250 Ω	Digital inputs	Switching threshold high 6...30 VDC Switching threshold low 0...1 VDC Digital input 5 – 7 can be used as frequency input (frequencies 0...5 kHz) and as PWM input (automatic frequency recognition)
Analog output	Enhanced amplifier: Voltage output ± 10 VDC Max. output current ± 3 mA Enhanced amplifier with HART: Current output 0...20 mA Max. output voltage 12 VDC	Digital outputs	Low-Side-Switch: $U_{max} = 40$ VDC $I_{max} = -700$ mA 0...500 s
Stabilised output voltage	10 VDC (with 24 VDC) 8 VDC (with 12 VDC) Max. load 30 mA	Ramps adjustable	0...500 s
		Serial interface	USB (plug type B) for parameterising with «PASO»
		EMV	
		Immunity	EN 61 000-6-2
		Emission	EN 61 000-6-4

DIMENSIONS

Type: SD730 Type: SD720

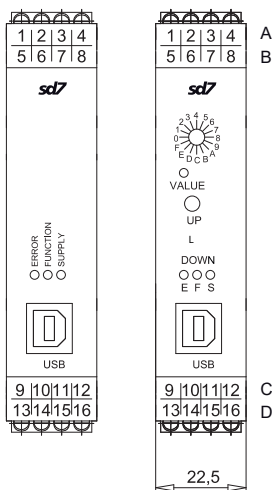

Type: Fieldbus

Type: SD735

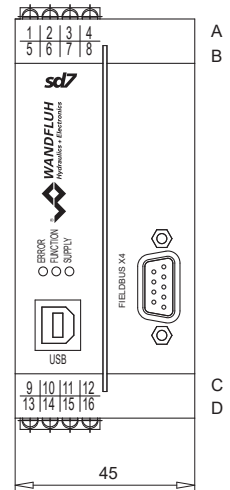
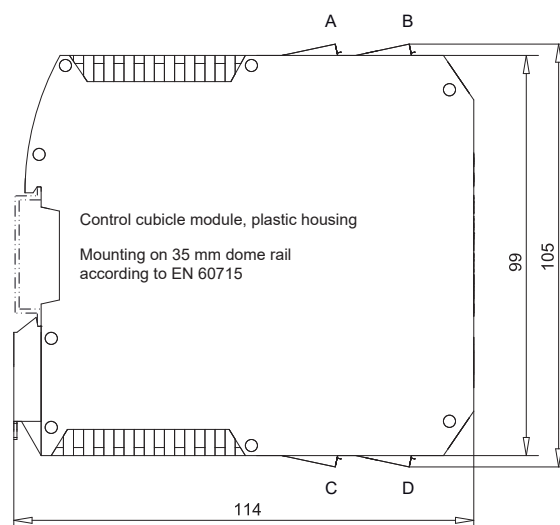

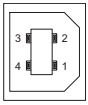
CONNECTOR WIRING DIAGRAM / PIN ASSIGNMENT
USB-interface, USB Type B X2

- 1 = VBUS
- 2 = D-
- 3 = D+
- 4 = GND

The parameterisation cable is not included in the delivery (commercially available USB cable, plug type A to plug type B)

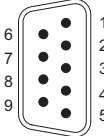
Device receptacle CANopen, J1939 (male) X4 (option)

- 1 = Reserved
- 2 = CANLow
- 3 = CANGnd
- 4 = Reserved
- 5 = CANSshield
- 6 = Reserved
- 7 = CANHigh
- 8 = Reserved
- 9 = Reserved

The mating connector (plug female, DSUB, 9-pole) is not included in the delivery.

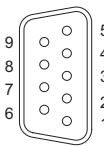
Device receptacle Profibus (female) X4 (option)

- 1 = Reserved
- 2 = Reserved
- 3 = RxD/TxD-P
- 4 = Reserved
- 5 = DGND
- 6 = VP
- 7 = Reserved
- 8 = RxD/TxD-N
- 9 = Reserved

The mating connector (plug male, DSUB, 9-pole) is not included in the delivery.

Basic amplifier

- 1 = Digital input 1
- 2 = Digital input 2
- 3 = Digital output 1
- 4 = Digital output 2
- 5 = Supply voltage +
- 6 = Supply voltage 0 VDC
- 7 = Stabilised output voltage
- 8 = Analog ground
- 9 = Analog input 1+
- 10 = Analog input 1-
- 11 = Analog input 2+
- 12 = Analog input 2-
- 13 = Output solenoid driver 2 +
- 14 = Output solenoid driver 2 -
- 15 = Output solenoid driver 1 +
- 16 = Output solenoid driver 1 -
- 21 = HART (option) Analog input 3 +
- 22 = HART (option) Analog input 3 -

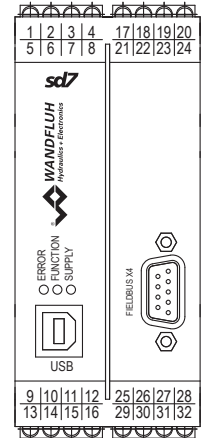
PIN-assignment X1

Additional Enhanced amplifier

- 17 = Digital input 3
- 18 = Digital input 4
- 19 = Digital input 5
- 20 = Digital input 6
- 21 = Digital input 7
- 22 = Digital input 8
- 23 = Digital output 3
- 24 = Digital output 4
- 25 = Analog input 3 +
- 26 = Analog input 3 -
- 27 = Analog input 4 +
- 28 = Analog input 4 -
- 29 = Digital ground
- 30 = Analog ground
- 31 = Stabilised output voltage
- 32 = Analog output

Enhanced amplifier with HART

- 17 = Analog output +
- 18 = Analog output -
- 19 = Digital input 3
- 20 = Digital input 4
- 21 = Analog input 3 + HART
- 22 = Analog input 3 - HART
- 23 = Analog input 4 +
- 24 = Analog input 4 -

FUNCTION DESCRIPTION

The amplifier module can be parameterised by means of the parameterisation software «PASO» through the USB-interface. In addition, the parameterisation software makes a data analysis possible. Optionally the amplifier module is equipped with a manual operation, which

enables the setting of the most important parameters by means of rotary selector switch and push-buttons and therefore makes a commissioning of the amplifier module possible without a PC.

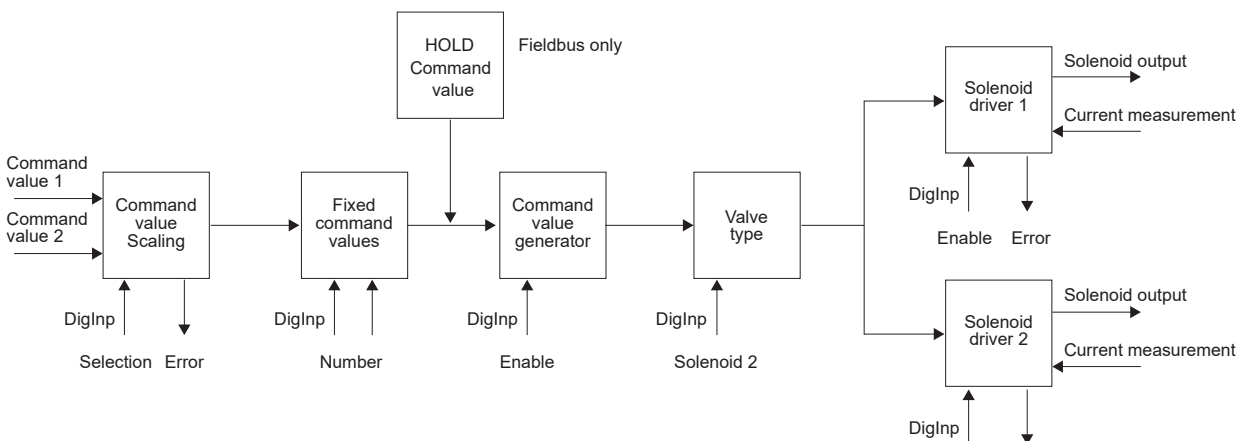

Command value scaling

The command value can be applied as a voltage, current or digital signal, or via fieldbus. For every command value, the input utilised can be selected. The scaling takes place via the parameters «Interface» and «Reference». Furthermore every command value can be monitored for a cable break (except for voltage and digital signal). For every command value a dead band can also be set. Optionally one can operate with two command values. The characteristic of these command values can be adjusted.

Fixed command values

- For the Basic amplifier, 3 fixed command values are available, which can be selected via 2 digital inputs.
- For the Enhanced amplifier, 7 fixed command values are available, which can be selected via 3 digital inputs.

Command value generator

For each solenoid output two linear ramps for up and down are available which can be adjusted separately.

HOLD command value (fieldbus only)

If via Profibus DP the device is put into the «HOLD» state, the respective command value is activated.

Valve type

Here the mode of operation is set. It is also possible to select whether proportional or switching solenoids are to be controlled.

Mode of operation «Command value unipolar (1-sol)»

Dependent on a unipolar command value signal (voltage, current), the solenoid is driven (e.g. 0...10V correspond to 0...100 % command value, 0...100 % command value correspond to I_{min} ... I_{max} solenoid driver 1).

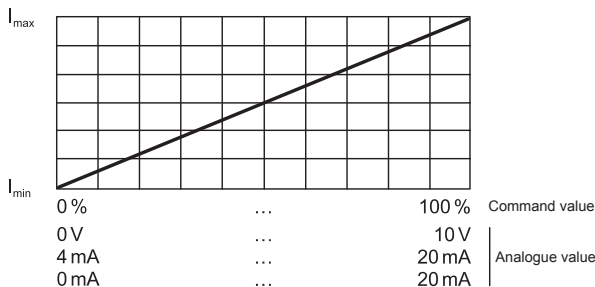

Mode of operation «Command value unipolar (2-sol)»

Dependent on a unipolar command value signal (voltage, current), according to the signal level one of the two solenoids is driven. The switching threshold between the two solenoids as standard is in the middle of the values range of the command value signal (e.g. 0...10V correspond to -100...+100 % command value, -100...0 % command value correspond to I_{min} ... I_{max} solenoid driver 2, 0...+100 % command value correspond to I_{min} ... I_{max} solenoid driver 1).

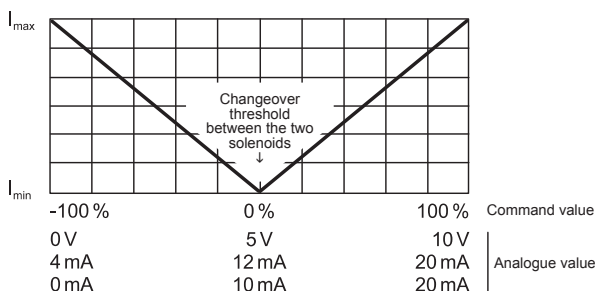

Mode of operation «Command value bipolar (2-sol)»

Dependent on a bipolar command value signal (voltage), according to the signal level one of the two solenoids is driven. The switching threshold between the two solenoids as standard is at 0V (e.g. -10...+10V correspond to -100...+100 % command value, -100...0 % command value correspond to I_{min} ... I_{max} solenoid driver 2, 0...+100 % command value correspond to I_{min} ... I_{max} solenoid driver 1).

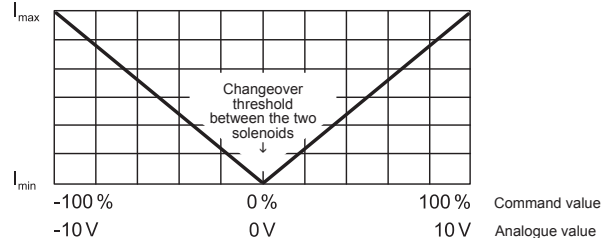

Mode of operation «Command value unipolar (2-sol with DigInp)»

Dependent on a unipolar command value signal (voltage, current), the solenoid is driven by solenoid driver 1, when the selected digital input is «not activated», resp. the solenoid by the solenoid driver 2, when the selected digital input is «activated» (e.g. 0...10V correspond to 0...100 % command value, 0...100 % command value correspond to I_{min} ... I_{max} solenoid driver 1 or 2).

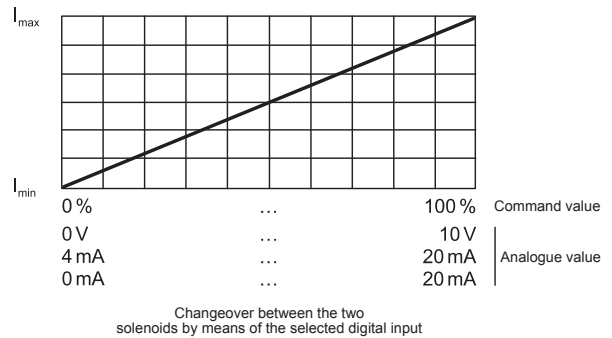

Signal recording

The SD7 amplifier module has a signal recording function. This, by means of PASO, enables the recording of various system signals, such as command value, solenoid currents, etc., which can be represented on a common time axis.

Solenoid driver

Two Pulse-Width-Modulated current outputs are available. To each output, a dither signal is superimposed, whereas dither frequency and dither level can be adjusted separately. For each output, the minimum (I_{min}) and maximum (I_{max}) current can be adjusted separately. The solenoid outputs can also be configured as switching outputs. Therewith for each output a power reduction can be adjusted separately.

Optimisation of characteristic curve

A characteristic curve adjustable per solenoid «Command value input – solenoid current output» enables an optimised (e.g., linearised) characteristic of the hydraulic system.

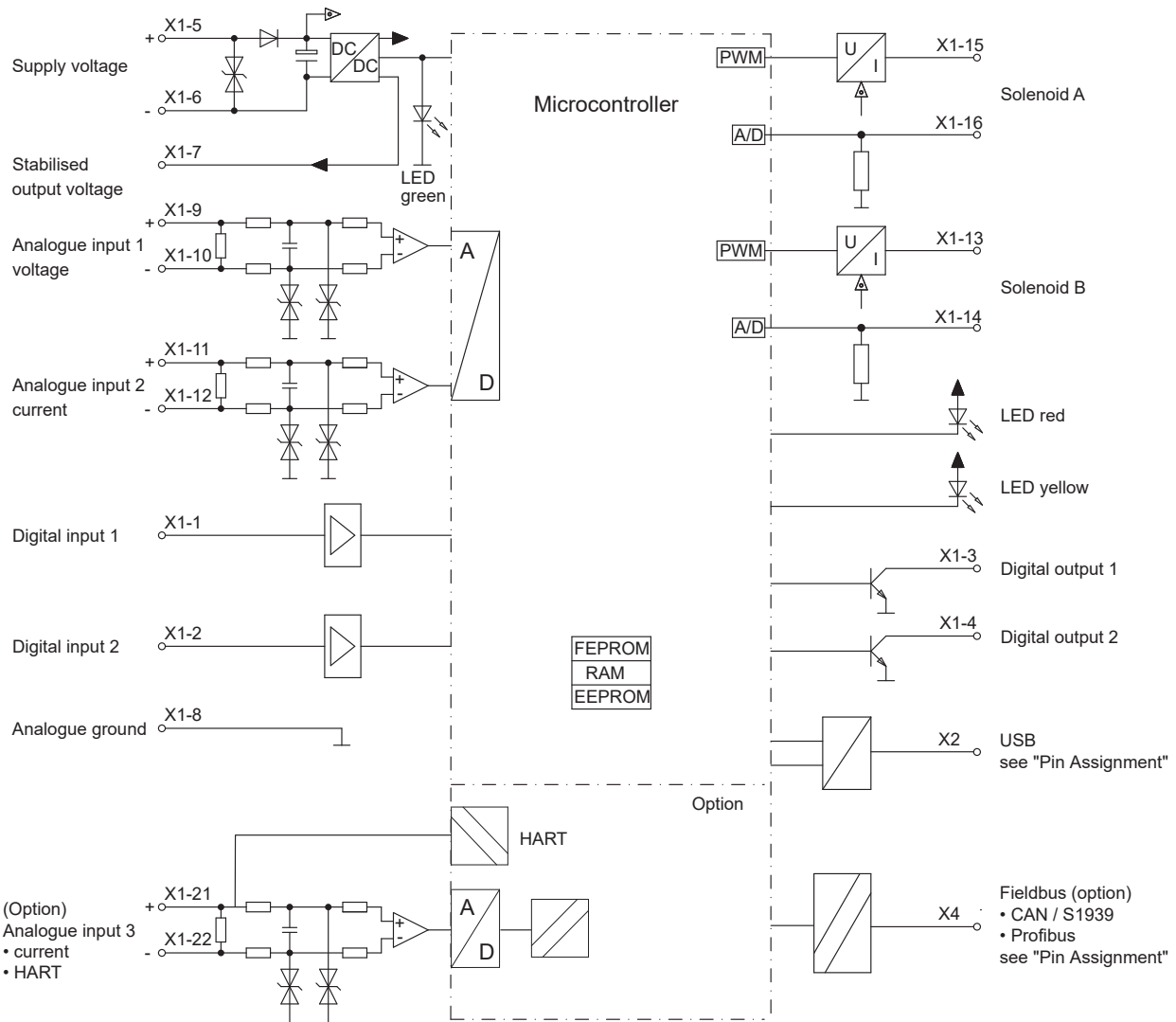
BLOCK DIAGRAM BASIC AMPLIFIER

Configuration Analog inputs Basic amplifier

Type designation	Analog input 1	Analog input 2
SD7x0xDx0-Ax	Voltage	Current
SD7x0xDx1-Ax	Voltage	Voltage*
SD7x0xDx2-Ax	Current	Current

* x = P only 0...10VDC possible

Configuration Analog inputs Enhanced amplifier

Type designation	Analog inputs			
	Nr. 1	Nr. 2	Nr. 3	Nr. 4
SD735xDx4-Bx	Voltage	Current	Voltage	Current
SD735xDx5-Bx	Voltage	Voltage*	Voltage	Voltage
SD735xDx6-Bx	Current	Current	Current	Current
SD735xDx7-Bx	Voltage	Voltage*	Current	Current
SD735xDx8-Bx	Current	Current	Voltage	Voltage

Configuration Analog inputs Basic amplifier HART

Type designation	Analog inputs		
	Nr. 1	Nr. 2	Nr. 3
SD7x0xDx0-BH	Voltage	Current	Current
SD7x0xDx1-BH	Voltage	Voltage	Current
SD7x0xDx2-BH	Current	Current	Current

Configuration Analog inputs Enhanced amplifier HART

Type designation	Analog inputs			
	Nr. 1	Nr. 2	Nr. 3	Nr. 4
SD735xDx4-BH	Voltage	Current	Current	Current
SD735xDx6-BH	Current	Current	Current	Current
SD735xDx7-BH	Voltage	Voltage	Current	Current

BLOCK DIAGRAM ENHANCED AMPLIFIER

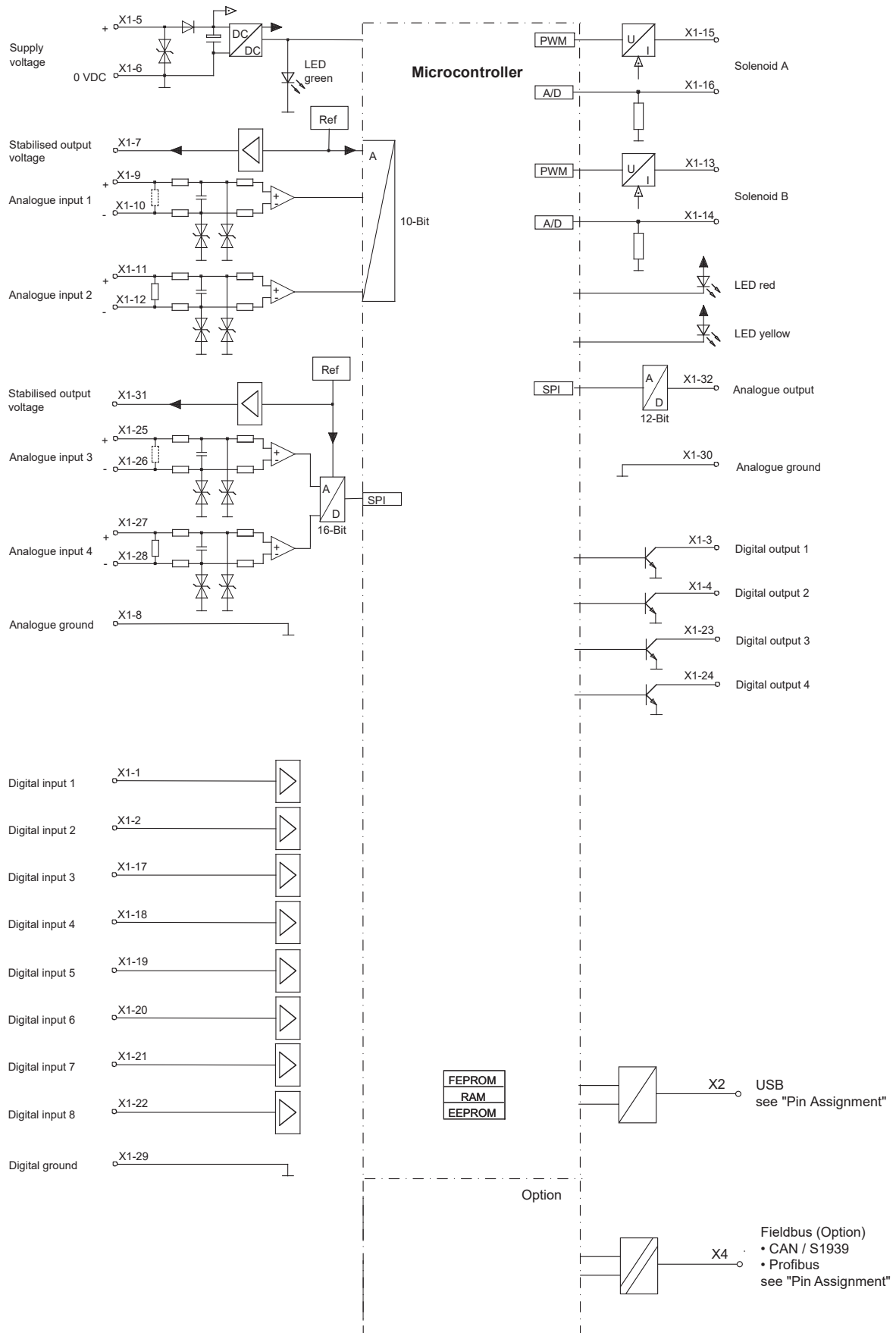

BLOCK DIAGRAM ENHANCED AMPLIFIER WITH HART

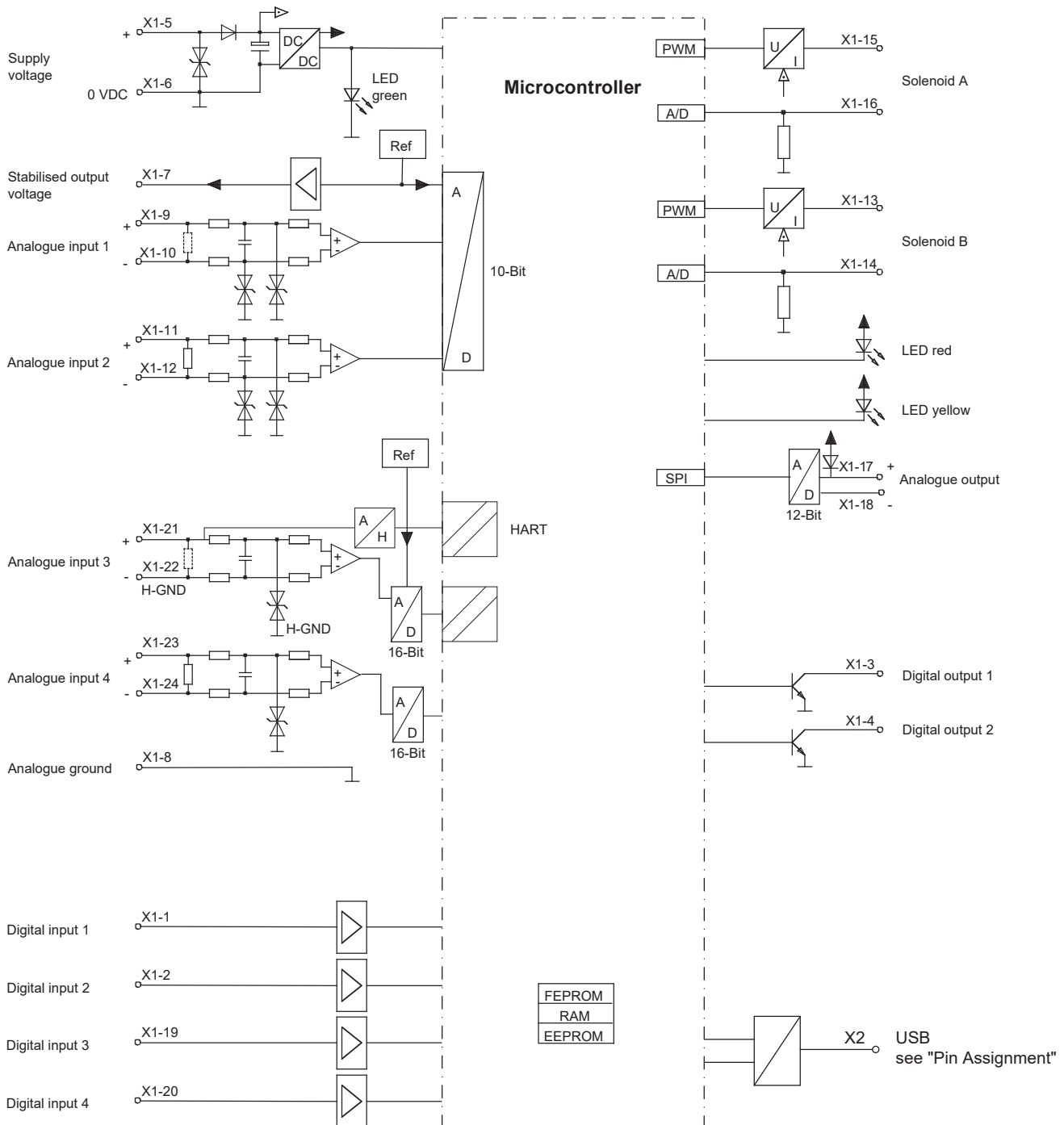

CONNECTION EXAMPLE BASIC AMPLIFIER

Mode of operation „Command value unipolar (2-sol)“ or „Command value unipolar (2-sol with DigInp)“

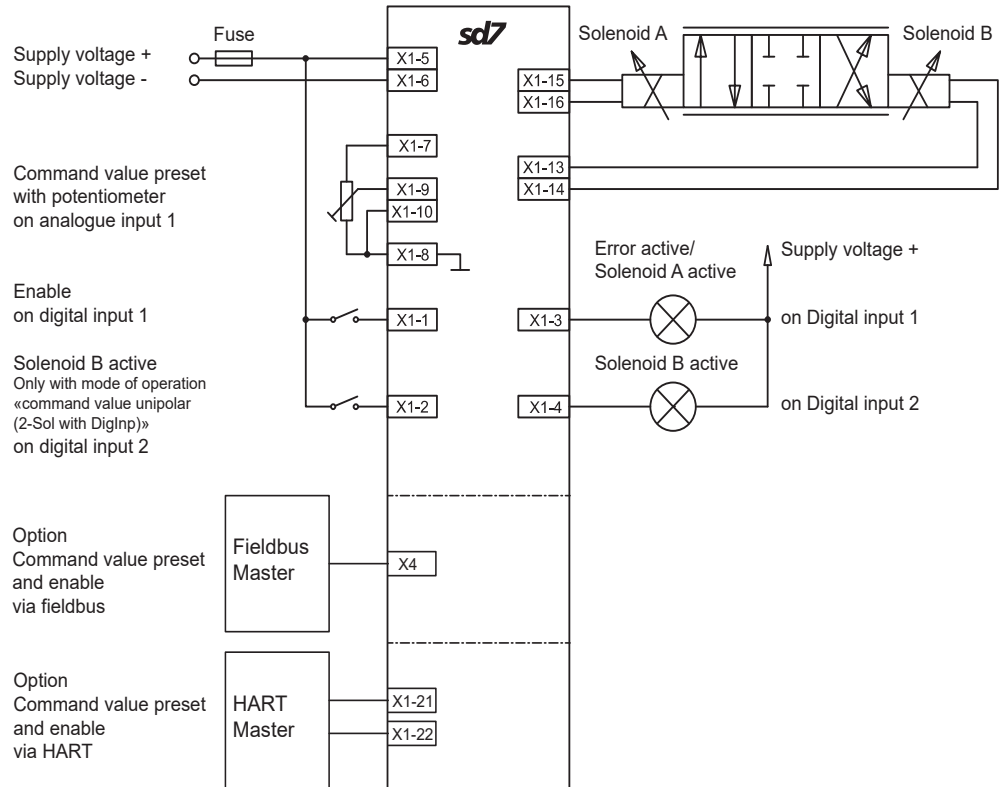

Mode of operation „Command value unipolar (1-sol)“

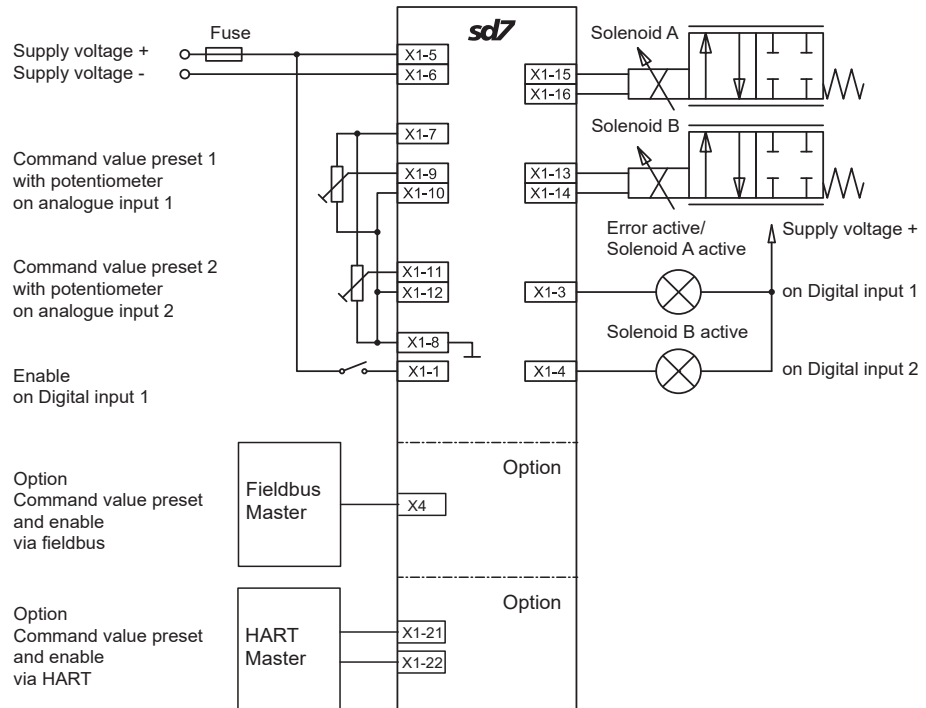

CONNECTION EXAMPLE ENHANCED AMPLIFIER

Mode of operation „Command value unipolar (2-sol)“ or „Command value unipolar (2-sol with DigInp)“

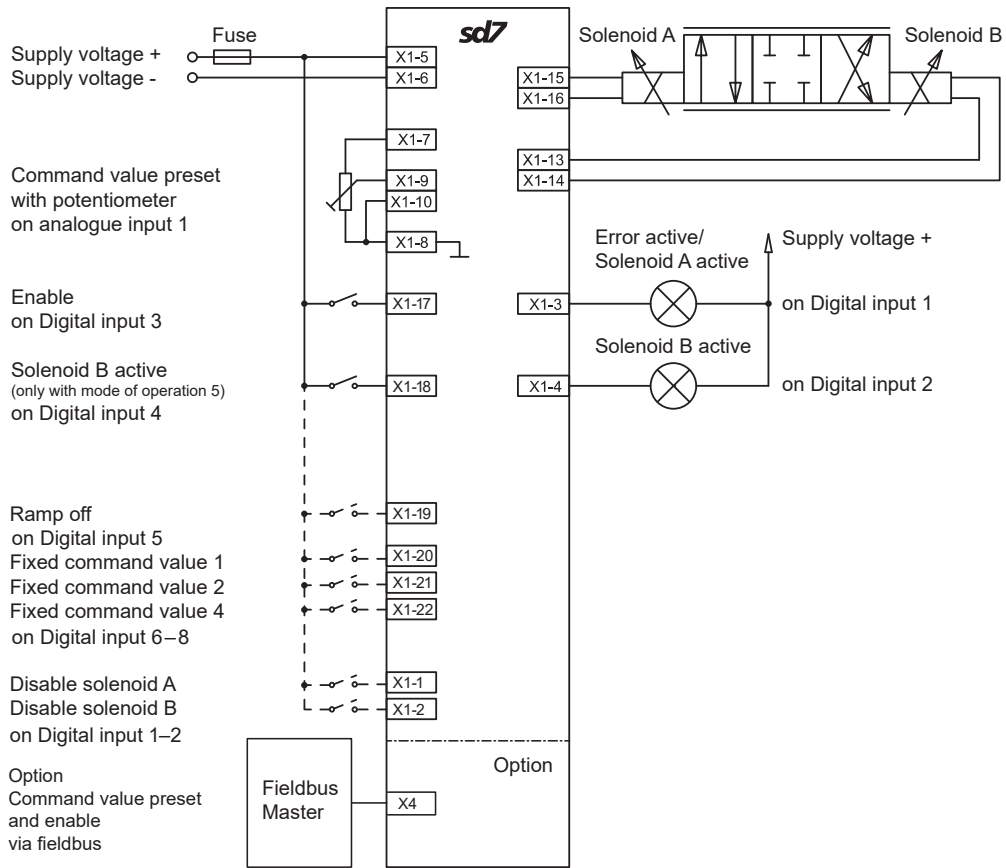

CONNECTION EXAMPLE ENHANCED AMPLIFIER WITH HART

Mode of operation „Command value unipolar (2-sol)“ or „Command value unipolar (2-sol with DigInp)“

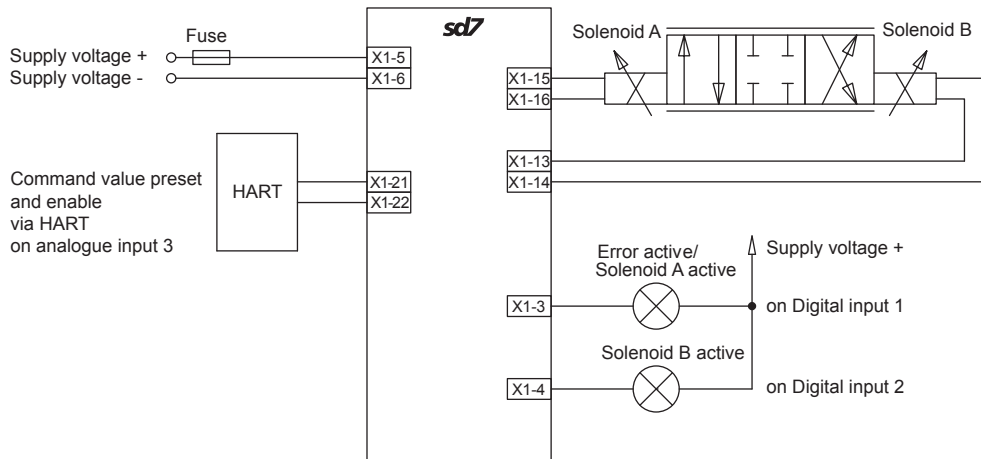

Архангельск (8182)63-90-72
Астана (7172)727-132
Астрахань (8512)99-46-04
Барнаул (3852)73-04-60
Белгород (4722)40-23-64
Брянск (4832)59-03-52
Владивосток (423)249-28-31
Волгоград (844)278-03-48
Вологда (8172)26-41-59
Воронеж (473)204-51-73
Екатеринбург (343)384-55-89
Иваново (4932)77-34-06

Ижевск (3412)26-03-58
Иркутск (395)279-98-46
Казань (843)206-01-48
Калининград (4012)72-03-81
Калуга (4842)92-23-67
Кемерово (3842)65-04-62
Киров (8332)68-02-04
Краснодар (861)203-40-90
Красноярск (391)204-63-61
Курск (4712)77-13-04
Липецк (4742)52-20-81

Магнитогорск (3519)55-03-13
Москва (495)268-04-70
Мурманск (8152)59-64-93
Набережные Челны (8552)20-53-41
Нижний Новгород (831)429-08-12
Новокузнецк (3843)20-46-81
Новосибирск (383)227-86-73
Омск (3812)21-46-40
Орел (4862)44-53-42
Оренбург (3532)37-68-04
Пенза (8412)22-31-16

Пермь (342)205-81-47
Ростов-на-Дону (863)308-18-15
Рязань (4912)46-61-64
Самара (846)206-03-16
Санкт-Петербург (812)309-46-40
Саратов (845)249-38-78
Севастополь (8692)22-31-93
Симферополь (3652)67-13-56
Смоленск (4812)29-41-54
Сочи (862)225-72-31
Ставрополь (8652)20-65-13

Сургут (3462)77-98-35
Тверь (4822)63-31-35
Томск (3822)98-41-53
Тула (4872)74-02-29
Тюмень (3452)66-21-18
Ульяновск (8422)24-23-59
Уфа (347)229-48-12
Хабаровск (4212)92-98-04
Челябинск (351)202-03-61
Череповец (8202)49-02-64
Ярославль (4852)69-52-93

Киргизия (996)312-96-26-47

Россия (495)268-04-70

Казахстан (772)734-952-31