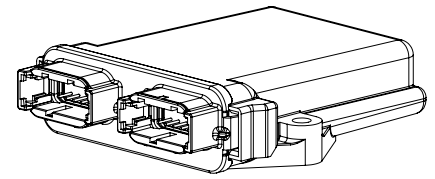

- Digital mobile electronics CL-307
- Robust construction with plug-in connection for mobile applications
- Protection class IP68
- 5/3 inputs / 8 outputs, for up to 4 pairs of proportional solenoids, or 8 switching solenoids, or 8 digital outputs
- CAN connection
- Freely programmable

DESCRIPTION

Microcontroller based control with multifunctional inputs/outputs of the PME devices family (Programmable Mobile Electronics). Delivered in a robust and compact plastic housing, it is designed for the hard use in working devices and is perfectly suitable for various open loop and closed loop control tasks.

FUNCTION

The control can be used and programmed as a stand alone unit, or as part of a distributed, decentralised system architecture. The variably usable inputs and outputs enable reading and controlling sensors and actuators of all kinds.

APPLICATION

This mobile electronics is used mainly in the mobile field because of the compact construction, protection class IP67 as well as the extensive operating temperature range and the selected plug connection. Customer-specific requirements can be easily implemented.

CONTENT

GENERAL SPECIFICATIONS	1
ELECTRICAL SPECIFICATIONS	1
DIMENSIONS, ASSEMBLY	2
ACCESSORIES	2
CONNECTOR WIRING DIAGRAM / PIN ASSIGNMENT	3

TYPE CODE

CL-307-101-WAG-00	Master I/O Module
CL-307-103-WAG-00	Client I/O Module

GENERAL SPECIFICATIONS

Execution	Plastic molded housing
Dimensions	119 x 36 x 133 mm (see Dimensions)
Mounting	Mounting flange, screwed on
Weight	250 g
Device receptacle	Deutsch DTM04-12PC/D pin header
Mating connectors	Deutsch DTM06-12SC / DTM06-12SD

Note: Mating connector not part of the delivery

Working temperature -40...+70°C

ELECTRICAL SPECIFICATIONS

Protection class	IP68
Supply voltage	8...32 VDC
No-load current	43 mA at 13.8 V, 27 mA at 28 V

Analogue Inputs

Number of inputs	3
Input voltage range	0...5.5 V
Input resistance	58.7 kOhm
Resolution	12 bit

Digital Inputs

Number of inputs	Master: 2, Client: none
Switching threshold	positive >3.5 V, negative <1.5 V

STG Switch To Ground input

Pull-up resistor	389 Ohm to internal 5 V
------------------	-------------------------

FREQ Frequency Input

Pull-up resistor	3.92 kOhm to internal 5 V
Resolution	< 5 Hz
Frequency range	max. 1 kHz (open drain, sinking sensor) max. 10 kHz (active push-pull sensor)

HID Harness Identification (Client addressing)

Digital outputs

Number of outputs	up to 8 / up to 4 x 2
Protection	Short to GND Short to Battery Overcurrent
Pull-up resistance	10 kOhm for diagnostics

DOUT Digital Outputs

maximum current	3.0 A (individual) 2.5 A (grouped)
-----------------	---------------------------------------

PWM Pulse Width Modulation Outputs

maximum current	3.0 A (individual) 2.0 A (grouped)
-----------------	---------------------------------------

ECC Estimated Current Feedback, 0.2-3.5 A/12 bit

Accuracy ECC	+/- 50mA at 2 A
--------------	-----------------

CC Constant Current (4 pairs)

current sensing	0..3.43 A / 12 bit
-----------------	--------------------

CAN

40 kbit/s to 250 kbit/s

Software

Apart from the programming tools, a software for diagnostics and error eliminating for the commissioning of the system is available.

Архангельск (8182)63-90-72
 Астана (7172)727-132
 Астрахань (8512)99-46-04
 Барнаул (3852)73-04-60
 Белгород (4722)40-23-64
 Брянск (4832)59-03-52
 Владивосток (423)249-28-31
 Волгоград (844)278-03-48
 Вологда (8172)26-41-59
 Воронеж (473)204-51-73
 Екатеринбург (343)384-55-89
 Иваново (4932)77-34-06

Ижевск (3412)26-03-58
 Иркутск (395)279-98-46
 Казань (843)206-01-48
 Калининград (4012)72-03-81
 Калуга (4842)92-23-67
 Кемерово (3842)65-04-62
 Киров (8332)68-02-04
 Краснодар (861)203-40-90
 Красноярск (391)204-63-61
 Курск (4712)77-13-04
 Липецк (4742)52-20-81

Магнитогорск (3519)55-03-13
 Москва (495)268-04-70
 Мурманск (8152)59-64-93
 Набережные Челны (8552)20-53-41
 Нижний Новгород (831)429-08-12
 Новокузнецк (3843)20-46-81
 Новосибирск (383)227-86-73
 Омск (3812)21-46-40
 Орел (4862)44-53-42
 Оренбург (3532)37-68-04
 Пенза (8412)22-31-16

Пермь (342)205-81-47
 Ростов-на-Дону (863)308-18-15
 Рязань (4912)46-61-64
 Самара (846)206-03-16
 Санкт-Петербург (812)309-46-40
 Саратов (845)249-38-78
 Севастополь (8692)22-31-93
 Симферополь (3652)67-13-56
 Смоленск (4812)29-41-54
 Сочи (862)225-72-31
 Ставрополь (8652)20-65-13

Сургут (3462)77-98-35
 Тверь (4822)63-31-35
 Томск (3822)98-41-53
 Тула (4872)74-02-29
 Тюмень (3452)66-21-18
 Ульяновск (8422)24-23-59
 Уфа (347)229-48-12
 Хабаровск (4212)92-98-04
 Челябинск (351)202-03-61
 Череповец (8202)49-02-64
 Ярославль (4852)69-52-93

Киргизия (996)312-96-26-47

Россия (495)268-04-70

Казахстан (772)734-952-31

DIMENSIONS

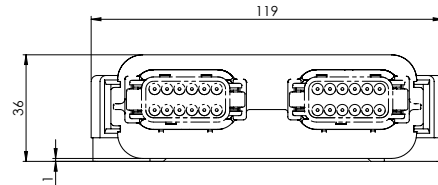
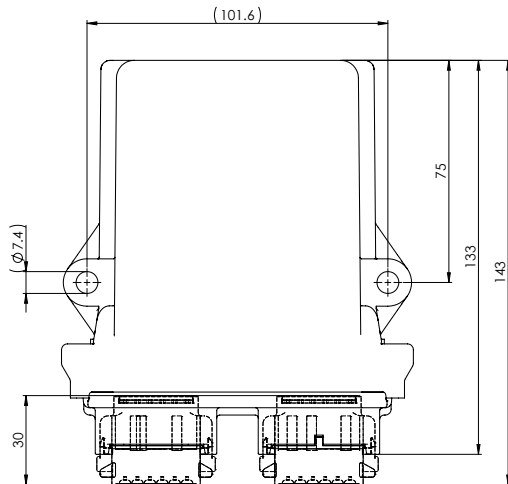

ASSEMBLY

Mounting surface

View from below

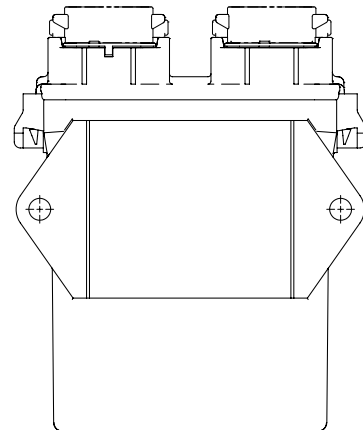
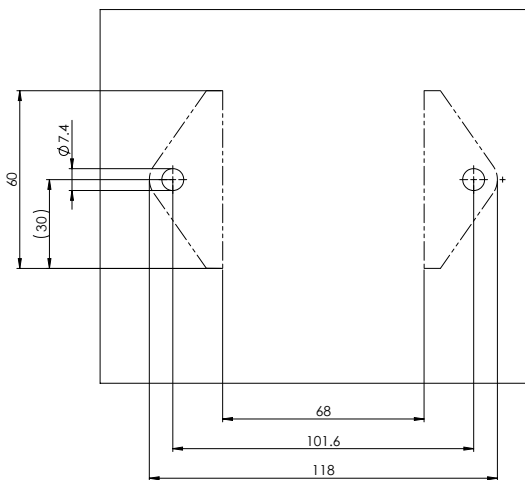

ACCESSORIES

Mating connector 1
Mating connector 2
Wedge lock
Crimp socket AWG 20, 0.5 mm²
or Crimp socket AWG 16-18, 0.75–1 mm²
Sealing plugs

Deutsch DTM06-12SC
Deutsch DTM06-12SD
Deutsch W12S (2 pcs)
Deutsch 0462-201-20141 (max. 24 pcs)
Deutsch 0462-005-20141 (max. 24 pcs)
Deutsch 0413-204-2005 (max. 24 pcs)

Orchestra Software Suite
Art. no. 740.1000

Project management software
Ladder-Logic and C-Code
Display GUI Programming incl. Conductor Software

Conductor Software
Art. no. 740.1001

Standalone diagnostics and set-up tool

NXP (Freescale) CodeWarrior
3rd party tool

C-Code Programming tool/Compiler

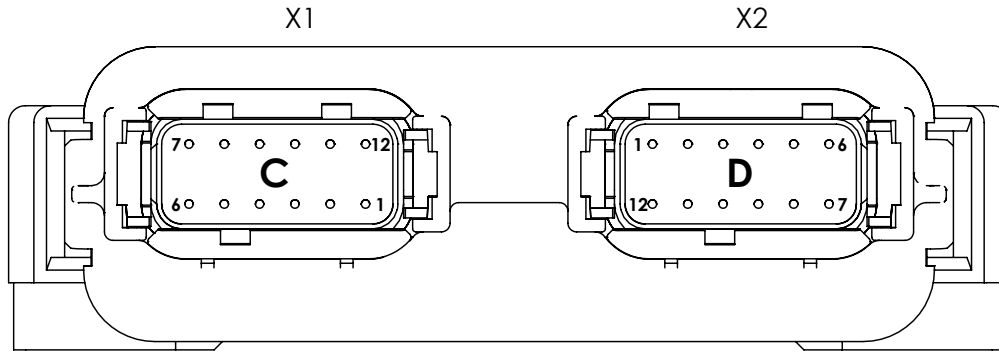
CONNECTOR WIRING DIAGRAM / PIN ASSIGNMENT

X1, green, 12-pole, connector C-coded

Pin	Function
1	Ground - Analog inputs
2	BAT(-) Module
3	CAN1-H
4	CAN1-L
5	BAT(+) Outputs 1-4
6	BAT(+) Module / Input #6 Battery Voltage
7	Output #1 DOUT(+) / PWM(+) / CC(+) (2A)
8	Output #2 DOUT(+) / PWM(+) / CC(+) (2A)
9	Output #3 DOUT(+) / PWM(+) / CC(+) (2A)
10	Output #4 DOUT(+) / PWM(+) / CC(+) (2A)
11	Return(-) Outputs 1-2
12	Return(-) Outputs 3-4

X2, brown, 12-pole, connector D-coded

Pin	Function
1	Return(-) Outputs 5-6
2	Return(-) Outputs 7-8
3	Output #5 DOUT(+) / PWM(+) / CC(+) (2A)
4	Output #6 DOUT(+) / PWM(+) / CC(+) (2A)
5	Output #7 DOUT(+) / PWM(+) / CC(+) (2A)
6	Output #8 DOUT(+) / PWM(+) / CC(+) (2A)
7	BAT(+) Outputs 5-8
8	Input #1 AIN (0-5.5VDC)
9	Input #2 AIN (0-5.5VDC)
10	Input #3 AIN (0-5.5VDC)
11	Master: Input #4 STG / FREQ; Client: HID 1
12	Master: Input #5 STG / FREQ; Client: HID 2

DOUT = Digital output
 CC = Constant current
 PWM = Pulse width modulation
 AIN = Analog input
 STG = Switch to ground input
 FREQ = Frequency input
 HID = Harness identification code digital inputs for addressing client modules

Архангельск (8182)63-90-72
 Астана (7172)727-132
 Астрахань (8512)99-46-04
 Барнаул (3852)73-04-60
 Белгород (4722)40-23-64
 Брянск (4832)59-03-52
 Владивосток (423)249-28-31
 Волгоград (844)278-03-48
 Вологда (8172)26-41-59
 Воронеж (473)204-51-73
 Екатеринбург (343)384-55-89
 Иваново (4932)77-34-06

Ижевск (3412)26-03-58
 Иркутск (395)279-98-46
 Казань (843)206-01-48
 Калининград (4012)72-03-81
 Калуга (4842)92-23-67
 Кемерово (3842)65-04-62
 Киров (8332)68-02-04
 Краснодар (861)203-40-90
 Красноярск (391)204-63-61
 Курск (4712)77-13-04
 Липецк (4742)52-20-81

Магнитогорск (3519)55-03-13
 Москва (495)268-04-70
 Мурманск (8152)59-64-93
 Набережные Челны (8552)20-53-41
 Нижний Новгород (831)429-08-12
 Новокузнецк (3843)20-46-81
 Новосибирск (383)227-86-73
 Омск (3812)21-46-40
 Орел (4862)44-53-42
 Оренбург (3532)37-68-04
 Пенза (8412)22-31-16

Пермь (342)205-81-47
 Ростов-на-Дону (863)308-18-15
 Рязань (4912)46-61-64
 Самара (846)206-03-16
 Санкт-Петербург (812)309-46-40
 Саратов (845)249-38-78
 Севастополь (8692)22-31-93
 Симферополь (3652)67-13-56
 Смоленск (4812)29-41-54
 Сочи (862)225-72-31
 Ставрополь (8652)20-65-13

Сургут (3462)77-98-35
 Тверь (4822)63-31-35
 Томск (3822)98-41-53
 Тула (4872)74-02-29
 Тюмень (3452)66-21-18
 Ульяновск (8422)24-23-59
 Уфа (347)229-48-12
 Хабаровск (4212)92-98-04
 Челябинск (351)202-03-61
 Череповец (8202)49-02-64
 Ярославль (4852)69-52-93

Киргизия (996)312-96-26-47

Россия (495)268-04-70

Казахстан (772)734-952-31