

- Digital mobile electronics CL-450
- Robust construction with plug-in connection for mobile applications
- Protection class IP68
- 69 inputs / 33 outputs, for up to 4 pairs of proportional solenoids and 25 switching solenoids / digital outputs
- CAN connection
- Freely programmable

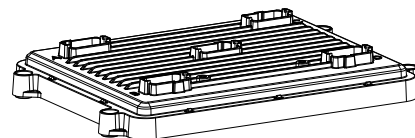

DESCRIPTION

Microcontroller based control with multifunctional inputs/outputs of the PME devices family (Programmable Mobile Electronics). Delivered in a robust and compact plastic housing, it is designed for the hard use in working devices and is perfectly suitable for various open loop and closed loop control tasks.

FUNCTION

The control can be used and programmed as a stand alone unit, or as part of a distributed, decentralised system architecture. The variably usable inputs and outputs enable reading and controlling sensors and actuators of all kinds. The free programmability enables maximum flexibility for the adaptation to any desired machine function.

APPLICATION

This mobile electronics is used mainly in the mobile field because of the compact construction, protection class IP67 as well as the extensive operating temperature range and the selected plug connection. Customer-specific requirements can be easily implemented.

CONTENT

GENERAL SPECIFICATIONS	1
ELECTRICAL SPECIFICATIONS	1
DIMENSIONS, ASSEMBLY	2
ACCESSORIES	2
CONNECTOR WIRING DIAGRAM / PIN ASSIGNMENT	3

TYPE CODE

CL-450-101-10-WAG-00	Master I/O Module
CL-450-101-20-WAG-00	Client I/O Module

GENERAL SPECIFICATIONS

Execution	Plastic molded housing
Dimensions	285 x 203 x 39 mm (see Dimensions)
Mounting	Mounting flange screwed on
Weight	620 g
Device receptacle	Deutsch DT18 pin headers
Mating connectors	Deutsch DT16-18SA/B/C/D/E-K004

Working temperature	-40...+70°C
MTBF	27 years (Telcordia SR-332)

Note Mating connector not part of the delivery

ELECTRICAL SPECIFICATIONS

Protection Class	IP68
Supply Voltage	8...32 VDC
No-load current	180 mA at 8 V, 88mA at 32 V
Analogue Inputs	
Number of inputs	up to 14
Input voltage range	Inputs #55-#58: 0-5.93 / 0-38.91 V Inputs #63-#72: 0-6 V / 0-24 mA
Input resistance	Inputs #55-#58: 120 k / 22.9 kOhm Inputs #63-#72: 53.9 k / 201.3 Ohm
Resolution	12 bit

See CONNECTOR WIRING DIAGRAM / PIN ASSIGNMENT
Special requirements

Digital Inputs

Number of inputs	up to 65
Switching threshold	positive > 3.5 V, negative < 1.0 V
STB Switch To Battery input (up to 65)	
Input resistance	2.6 kOhm
STG Switch To Ground input (up to 43)	
Pull-up resistance	560 Ohm to internal 5 V
FREQ Frequency Input (up to 4)	
Pull-up resistance	4.7 kOhm to internal 5V
Resolution	< 5 Hz
Frequency Range	max 10 kHz
RTD Resistance to digital (up to 6)	
Pull-up resistor	Inputs #63/64/67: 499 Ohm Inputs #68/70/71: 2 kOhm
Accuracy	+/- 2 %

Digital Outputs

Number of outputs	up to 33
Protection	Short to GND Short to Battery Overcurrent
Pull-up/down	560 Ohm / 2.6 kOhm for diagnostics
DOUT Digital Outputs	
maximum current	3.0 A (individual) 3.0 A (grouped)
PWM Pulse Width Modulation Outputs	
maximum current	3.0 A (individual) 2.0 A (grouped)
2 x 4 CC	Constant Current (4 complementary pairs)
Current sensing	0..3.84 A / 12 bit
ECC Estimated Current feedback, 0.2-4 A / 10 bit	
Accuracy ECC	+/- 50mA at 2A

Sensor output

Supply	5 V +/- 4 %, 250 mA
CAN	3x 40 kbit/s to 500 kbit/s

Software

Apart from the programming tools, a software for diagnostics and error eliminating for the commissioning of the system is available.

Архангельск (8182)63-90-72
Астана (7172)727-132
Астрахань (8512)99-46-04
Барнаул (3852)73-04-60
Белгород (4722)40-23-64
Брянск (4832)59-03-52
Владивосток (423)249-28-31
Волгоград (844)278-03-48
Волгодда (8172)26-41-59
Воронеж (473)204-51-73
Екатеринбург (343)384-55-89
Иваново (4932)77-34-06

Ижевск (3412)26-03-58
Иркутск (395)279-98-46
Казань (843)206-01-48
Калининград (4012)72-03-81
Калуга (4842)92-23-67
Кемерово (3842)65-04-62
Киров (8332)68-02-04
Краснодар (861)203-40-90
Красноярск (391)204-63-61
Курск (4712)77-13-04
Липецк (4742)52-20-81

Магнитогорск (3519)55-03-13
Москва (495)268-04-70
Мурманск (8152)59-64-93
Набережные Челны (8552)20-53-41
Нижний Новгород (831)429-08-12
Новокузнецк (3843)20-46-81
Новосибирск (383)227-86-73
Омск (3812)21-46-40
Орел (4862)44-53-42
Оренбург (3532)37-68-04
Пенза (8412)22-31-16

Пермь (342)205-81-47
Ростов-на-Дону (863)308-18-15
Рязань (4912)46-61-64
Самара (846)206-03-16
Санкт-Петербург (812)309-46-40
Саратов (845)249-38-78
Севастополь (8692)22-31-93
Симферополь (3652)67-13-56
Смоленск (4812)29-41-54
Сочи (862)225-72-31
Ставрополь (8652)20-65-13

Сургут (3462)77-98-35
Тверь (4822)63-31-35
Томск (3822)98-41-53
Тула (4872)74-02-29
Тюмень (3452)66-21-18
Ульяновск (8422)24-23-59
Уфа (347)229-48-12
Хабаровск (4212)92-98-04
Челябинск (351)202-03-61
Череповец (8202)49-02-64
Ярославль (4852)69-52-93

Киргизия (996)312-96-26-47

Россия (495)268-04-70

Казахстан (772)734-952-31

DIMENSIONS

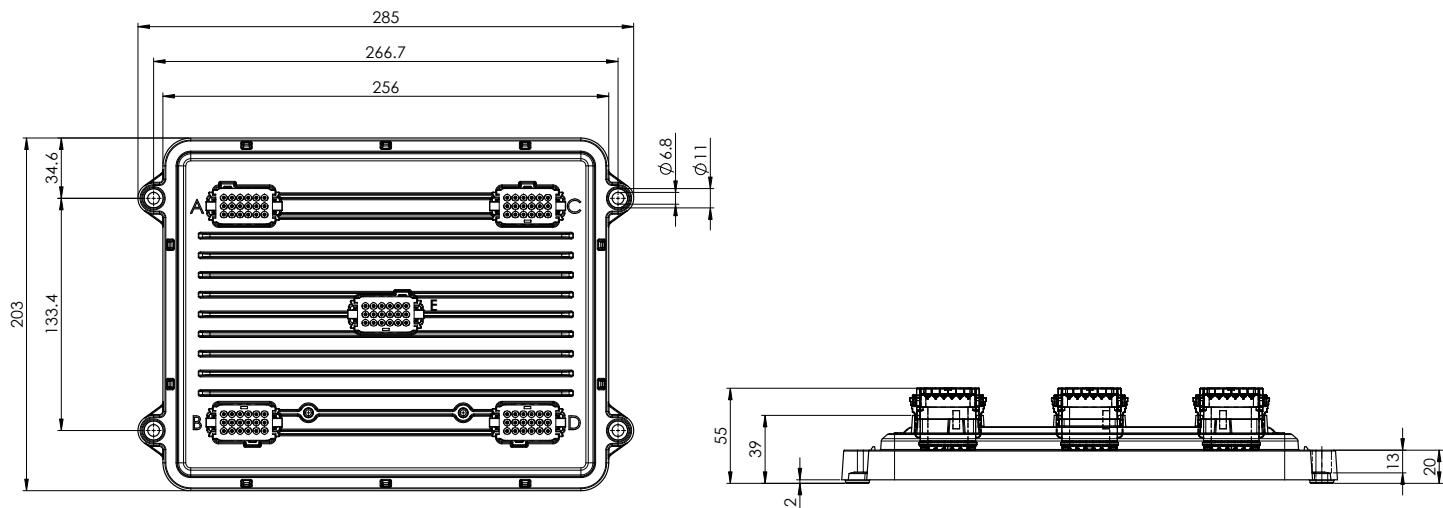

ACCESSORIES

Mating connector 1	Deutsch DT16-18SA-K004
Mating connector 2	Deutsch DT16-18SB-K004
Mating connector 3	Deutsch DT16-18SC-K004
Mating connector 4	Deutsch DT16-18SD-K004
Mating connector 5	Deutsch DT16-18SE-K004
Crimp socket AWG 16-20, 0.5-1.5 mm ²	Deutsch 0462-201-16141 (max. 80 pcs)
or crimp socket AWG 14, max. 2 mm ²	Deutsch 0462-209-16141 (max. 80 pcs)
Sealing plug	Deutsch 114017 (max. 80 pcs)
or snapping sealing plug	Deutsch 0413-217-1605

Orchestra Software Suite Art. no. 740.1000	Project management software Ladder-Logic and C-Code Display GUI Programming incl. Conductor Software
Conductor Software Art. no. 740.1001	Standalone diagnostics and set-up tool
NXP (Freescale) CodeWarrior 3rd party tool	C-Code Programming tool/Compiler

CONNECTOR WIRING DIAGRAM / PIN ASSIGNMENT

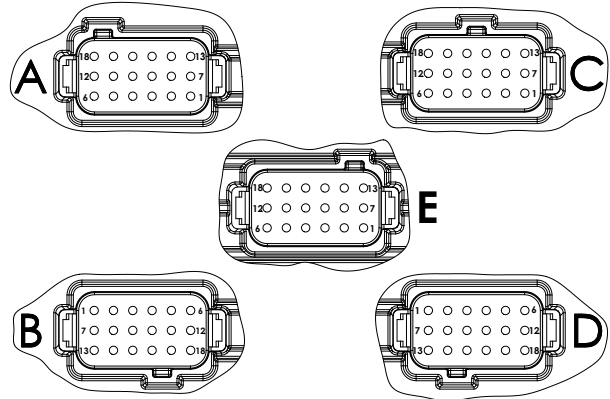
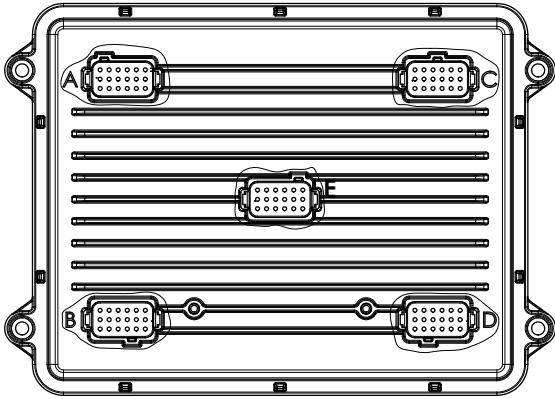

X1 (A), 18-pole, Connector A-coded

Pin	Function
1*	Input #1 STB / STG Output #1 DOUT(+) / PWM(+) / ECC
2*	Input #2 STB / STG Output #2 DOUT(+) / PWM(+) / ECC
3*	Input #3 STB / STG Output #3 DOUT(+) / PWM(+) / ECC
4*	Input #4 STB / STG Output #4 DOUT(+) / PWM(+) / ECC
5	BAT(-) Module
6	Steady plus BAT(+) Module and Outputs 1-8
7	CAN1-H
8	CAN1-L
9*	Input #5 STB / STG Output #5 DOUT(+) / PWM(+) / ECC
10*	Input #6 STB / STG Output #6 DOUT(+) / PWM(+) / ECC
11	Switched BAT(+) Input #7 Battery Voltage
12	Return(-) Outputs 7 - 8
13*	Input #8 STB / STG Output #7 DOUT(+) / PWM(+) / CC
14*	Input #9 STB / STG Output #8 DOUT(+) / PWM(+) / CC
15	Input #10 STB
16	Input #11 STB
17	Input #12 STB
18	Input #13 STB

X2 (B), 18-pole, Connector B-coded

Pin	Function
1*	Input #14 STB / STG Output #9 DOUT(+) / PWM(+) / ECC
2*	Input #15 STB / STG Output #10 DOUT(+) / PWM(+) / ECC
3*	Input #16 STB / STG Output #11 DOUT(+) / PWM(+) / ECC
4*	Input #17 STB / STG Output #12 DOUT(+) / PWM(+) / ECC
5	BAT(-) Module
6	BAT(+) Outputs 9-16
7	CAN2-H
8	CAN2-L
9*	Input #18 STB / STG Output #13 DOUT(+) / PWM(+) / ECC
10*	Input #19 STB / STG Output #14 DOUT(+) / PWM(+) / ECC
11	Input #20 STB
12	Return(-) Outputs 15 - 16
13*	Input #21 STB / STG Output #15 DOUT(+) / PWM(+) / CC
14*	Input #22 STB / STG Output #16 DOUT(+) / PWM(+) / CC
15	Input #23 STB
16	Input #24 STB
17	Input #25 STB
18	Input #26 STB

X3 (C), 18-pole, Connector C-coded

Pin	Function
1*	Input #27 STB / STG Output #17 DOUT(+) / PWM(+) / ECC
2*	Input #28 STB / STG Output #18 DOUT(+) / PWM(+) / ECC
3*	Input #29 STB / STG Output #19 DOUT(+) / PWM(+) / ECC
4*	Input #30 STB / STG Output #20 DOUT(+) / PWM(+) / ECC
5	BAT(-) Module
6	BAT(+) Outputs 17-24
7	CAN3-H
8	CAN3-L
9*	Input #31 STB / STG Output #21 DOUT(+) / PWM(+) / ECC
10*	Input #32 STB / STG Output #22 DOUT(+) / PWM(+) / ECC
11	Input #33 STB
12	Return(-) Outputs 23 - 24
13*	Input #34 STB / STG Output #23 DOUT(+) / PWM(+) / CC
14*	Input #35 STB / STG Output #24 DOUT(+) / PWM(+) / CC
15	Input #36 STB
16	Input #37 STB
17	Input #38 STB
18	Input #39 STB

X4 (D), 18-pole, Connector D-coded

Pin	Function
1*	Input #40 STB / STG Output #25 DOUT(+) / PWM(+) / ECC
2*	Input #41 STB / STG Output #26 DOUT(+) / PWM(+) / ECC
3*	Input #42 STB / STG Output #27 DOUT(+) / PWM(+) / ECC
4*	Input #43 STB / STG Output #28 DOUT(+) / PWM(+) / ECC
5	BAT(-) Module
6	BAT(+) Outputs 25-33
7*	Input #44 STB / STG Output #29 DOUT(+) / PWM(+) / ECC
8	Input #45 STB
9*	Input #46 STB / STG Output #30 DOUT(+) / PWM(+) / ECC
10*	Input #47 STB / STG Output #31 DOUT(+) / PWM(+) / ECC
11	Input #48 STB
12	Return(-) Outputs 32 - 33
13*	Input #49 STB / STG Output #32 DOUT(+) / PWM(+) / CC
14*	Input #50 STB / STG Output #33 DOUT(+) / PWM(+) / CC
15	Input #51 STB
16	Input #52 STB
17	Input #53 STB
18	Input #54 STB

X5 (E), 18-pole, Connector E-coded

Pin	Function
1	Input #55 VTD1(0-5.5V) / VTD2(0-35V)
2	Input #56 VTD1(0-5.5V) / VTD2(0-35V)
3	Input #57 VTD1(0-5.5V) / VTD2(0-35V)
4	Input #58 VTD1(0-5.5V) / VTD2(0-35V)
5	5VDC Sensor Supply (250mA)
6	5VDC Sensor Supply (250mA)
7	Input #61 STB
8	Input #62 STB
9	Input #63 STB / STG / VTD(0-5.5V) / RTD(500Ohm) / 20mA
10	Input #64 STB / STG / VTD(0-5.5V) / RTD(500Ohm) / 20mA
11	Input #65 STB / STG / VTD(0-5.5V) / FREQ / Count / PWM / Encoder(1A)
12	Input #66 STB / STG / VTD(0-5.5V) / FREQ / Count / PWM / Encoder(1B)
13	Input #67 STB / STG / VTD(0-5.5V) / RTD(500Ohm) / 20mA
14	Input #68 STB / STG / VTD(0-5.5V) / RTD(2kOhm) / 20mA
15	Input #69 STB / STG / VTD(0-5.5V) / FREQ / Count / PWM / Encoder(2A)
16	Input #70 STB / STG / VTD(0-5.5V) / RTD(2kOhm) / 20mA
17	Input #71 STB / STG / VTD(0-5.5V) / RTD(2kOhm) / 20mA
18	Input #72 STB / STG / VTD(0-5.5V) / FREQ / Count / PWM / Encoder(2B)

DOUT = digital output
 CC = constant current
 ECC = estimated current feedback
 PWM = pulse with modulation
 VTD = analog input
 STG = switch to ground (input)
 STB = switch to battery (input)
 FREQ = frequency input

*) Special requirements:

The input and output pins are linked together in a connector strip (Bank). All pins within one connector strip have to be configured in the same way. Either all pins as outputs, or as STB/STG inputs.

Bank 1: X1 (A) pin 1 / pin 2 / pin 13 / pin 14
 Bank 2: X2 (B) pin 1 / pin 2 / pin 13 / pin 14
 Bank 3: X3 (C) pin 1 / pin 2 / pin 13 / pin 14
 Bank 4: X4 (D) pin 1 / pin 2 / pin 13 / pin 14
 Bank 5: X1 (A) pin 3 / pin 4 / pin 9 / pin 10
 X2 (B) pin 3 / pin 4 / pin 9 / pin 10
 X3 (C) pin 3 / pin 4 / pin 9 / pin 10
 X4 (D) pin 3 / pin 4 / pin 7 / pin 9 / pin 10

Архангельск (8182)63-90-72
 Астана (7172)727-132
 Астрахань (8512)99-46-04
 Барнаул (3852)73-04-60
 Белгород (4722)40-23-64
 Брянск (4832)59-03-52
 Владивосток (423)249-28-31
 Волгоград (844)278-03-48
 Вологда (8172)26-41-59
 Воронеж (473)204-51-73
 Екатеринбург (343)384-55-89
 Иваново (4932)77-34-06

Ижевск (3412)26-03-58
 Иркутск (395)279-98-46
 Казань (843)206-01-48
 Калининград (4012)72-03-81
 Калуга (4842)92-23-67
 Кемерово (3842)65-04-62
 Киров (8332)68-02-04
 Краснодар (861)203-40-90
 Красноярск (391)204-63-61
 Курск (4712)77-13-04
 Липецк (4742)52-20-81

Магнитогорск (3519)55-03-13
 Москва (495)268-04-70
 Мурманск (8152)59-64-93
 Набережные Челны (8552)20-53-41
 Нижний Новгород (831)429-08-12
 Новокузнецк (3843)20-46-81
 Новосибирск (383)227-86-73
 Омск (3812)21-46-40
 Орел (4862)44-53-42
 Оренбург (3532)37-68-04
 Пенза (8412)22-31-16

Пермь (342)205-81-47
 Ростов-на-Дону (863)308-18-15
 Рязань (4912)46-61-64
 Самара (846)206-03-16
 Санкт-Петербург (812)309-46-40
 Саратов (845)249-38-78
 Севастополь (8692)22-31-93
 Симферополь (3652)67-13-56
 Смоленск (4812)29-41-54
 Сочи (862)225-72-31
 Ставрополь (8652)20-65-13

Сургут (3462)77-98-35
 Тверь (4822)63-31-35
 Томск (3822)98-41-53
 Тула (4872)74-02-29
 Тюмень (3452)66-21-18
 Ульяновск (8422)24-23-59
 Уфа (347)229-48-12
 Хабаровск (4212)92-98-04
 Челябинск (351)202-03-61
 Череповец (8202)49-02-64
 Ярославль (4852)69-52-93

Киргизия (996)312-96-26-47

Россия (495)268-04-70

Казахстан (772)734-952-31